



Installation Time 45-60 Minutes	Skill Level 	Kit Part number AMM2DJ- 002A64-C <hr/> I-Sheet AMM2DJ- 002A64C - I <hr/> Product code GFX-PPF <hr/> Release Date February 2022 <hr/> Vehicle Model Various
		

Components included - 6 Piece Side kit (may not be exactly as shown)

Front Fender

Front door

Rear Door

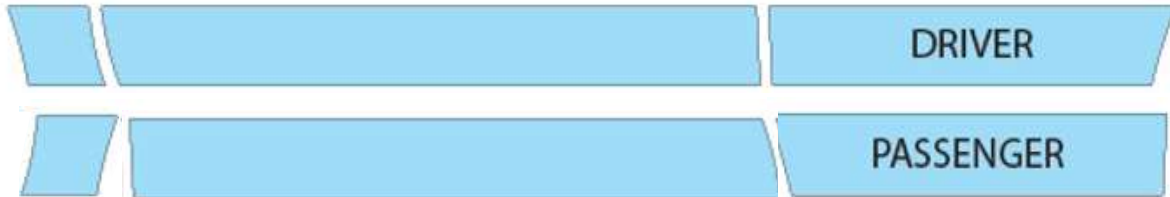

IMPORTANT: It is recommended that only qualified and trained personnel install this product

Tools needed



Tack Solution Spray Bottle (15% ISO/ 85% Water @ 99% ISO Base)



Soap Solution Spray Bottle



Alcohol Cleaner



Heat Gun (Any Brand)



Application Squeegee. 4" Black Smoothie



3M Hard Card



Mounting Solution(s). Diluted Baby Johnson's Shampoo or Fusion ALL Type.



3M Primer 94



Microfiber Towels



Clay Bar (Any Brand)

GENERAL PREPARATION

1

The ideal place to install Paint Protection Film (PPF) is in a clean, preferably dust controlled, environment between 65°F and 90°F (18°C to 32°C).

2

Surface Preparation: Wash the vehicle or at minimum the affected area with a degreasing soap & water mixture. With soap mixture still on vehicle, follow through with a clay bath (clay bar) polish. Rinse clean and dry (Microfiber towel) or let dry. Just prior to PPF install, follow through with a final clean wipe of 99% isopropyl alcohol using a micro-fiber towel. Be sure to wipe clean all edges where product will adhere to, including wrapped edges underneath hood and side fenders. **NOTE:** Be *ALERT* to clean surface well past the area being covered with PPF to avoid possible re-contamination during the installation process. Consider the use of compressed air to remove water. ⚠

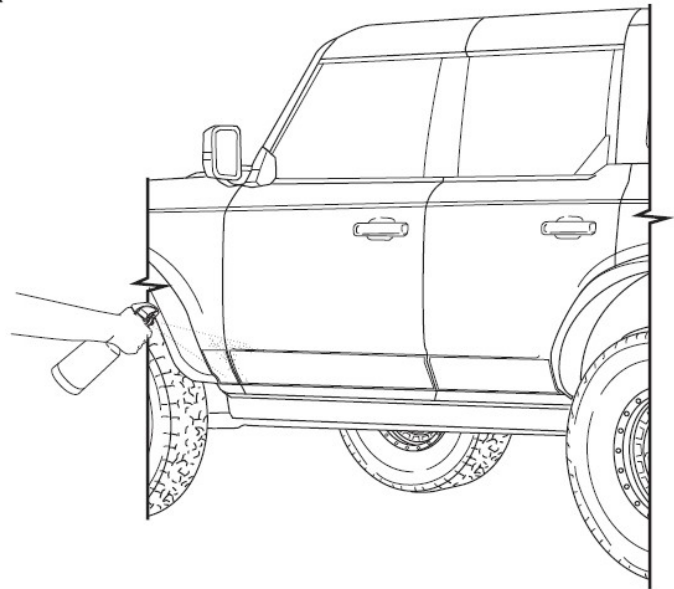

3

Tool Station(s): (a) Work Table(s): To ensure a contaminate free installation, it is advisable to have a flat surface water resistant working table, large enough to lay down PPF parts, next to the vehicle for the purpose of preparing the part prior to installation on the vehicle. **(b) Tool Cart(s) or Table:** An area to have installation tools, spray bottles, etc. next to vehicle and readily accessible. It is advised not to leave spray bottles on vehicle during installation or place on the ground where dust and debris can be collected and transferred onto vehicle.

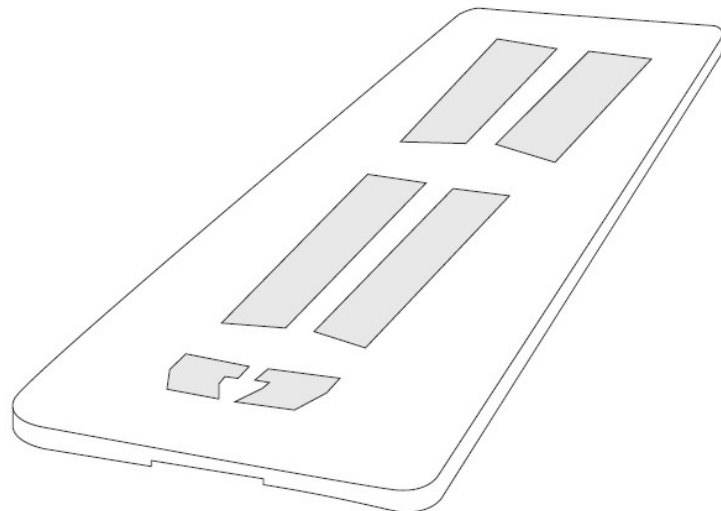

INSTALLATION PROCESS

- 4** Spray your hands with mounting solution. Lay film, adhesive side up on clean flat table. Separate backing liner from the film while spraying mounting solution on the adhesive. Be sure to completely soak the adhesive side of the film ensuring there are no dry spots.

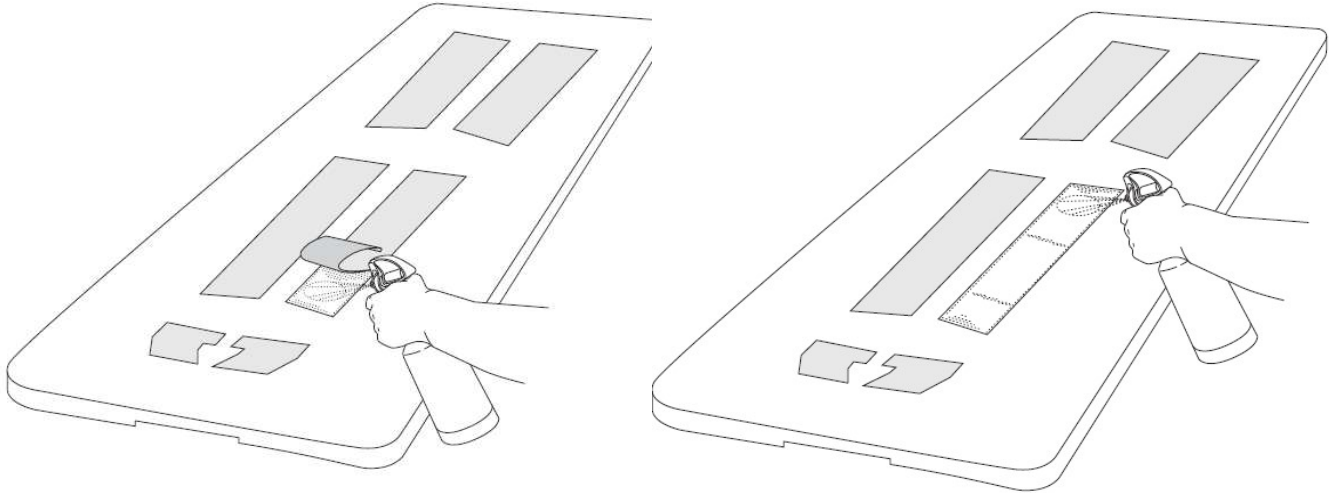

- 5** Next, spray mounting solution generously on the area in which Paint Protection Film will be applied. Gently position the film on the surface to be protected while identifying an alignment point such as the center, an emblem or a corner on the surface. This will be the starting point of the wet out.

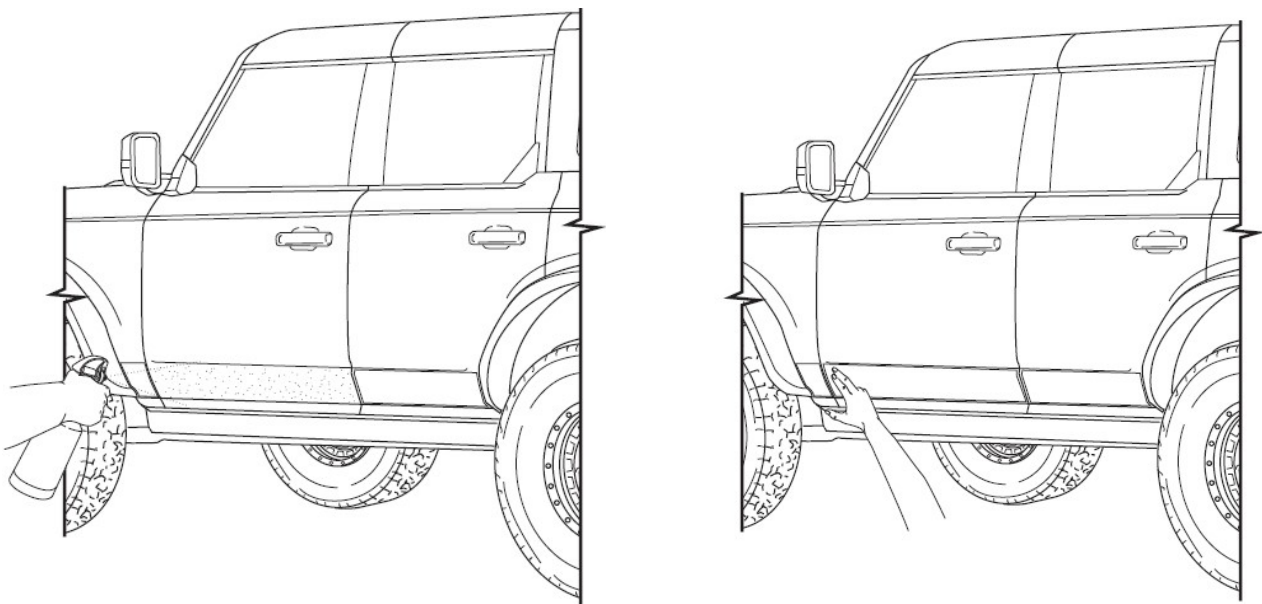

6

Spray film surface with the mounting solution and squeegee the alignment point in place, using the squeegee. This will hold the film in place for the next steps. If movement persists, spray tack area with Tack solution to initiate quicker bond. Ensure film is generously soaked in mounting solution prior to final squeegee process by lifting the film and spraying mounting solution underneath the film, as necessary. Then Squeegee, working from center out towards edges. Keep squeegeeing with overlapping strokes until most of the solution is wet out.

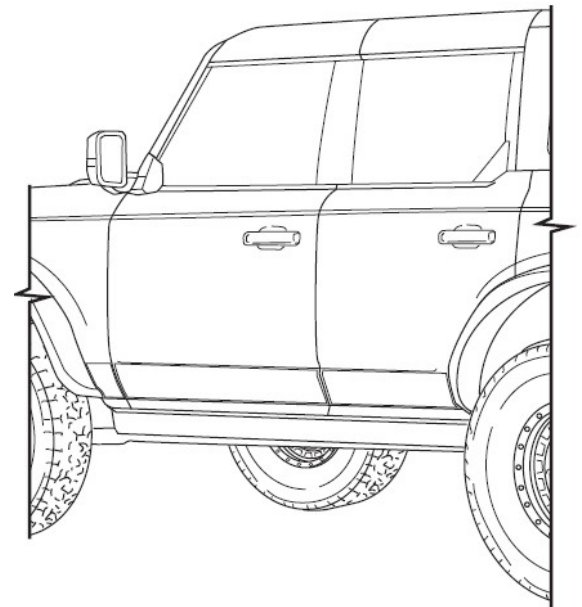
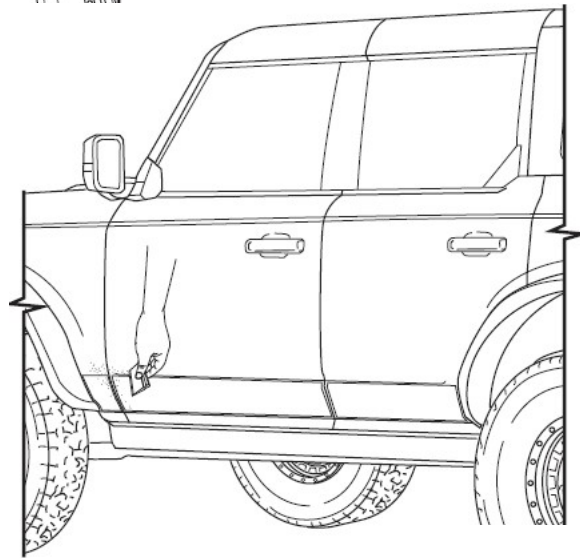
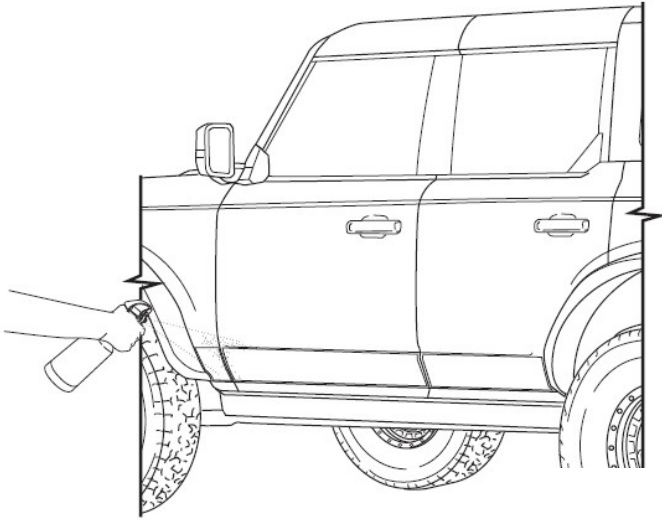

7

Stretch the film as necessary to align along the edges. Precut patterns account for most “fingers” in the design, so when stretching to align edges, most “fingers” will lay flat on the surface. “Fingers” are localized gaps in the film in aera of high contour. Continue to squeegee out the aid solution towards the edges as you stretch and align the film on the surface.

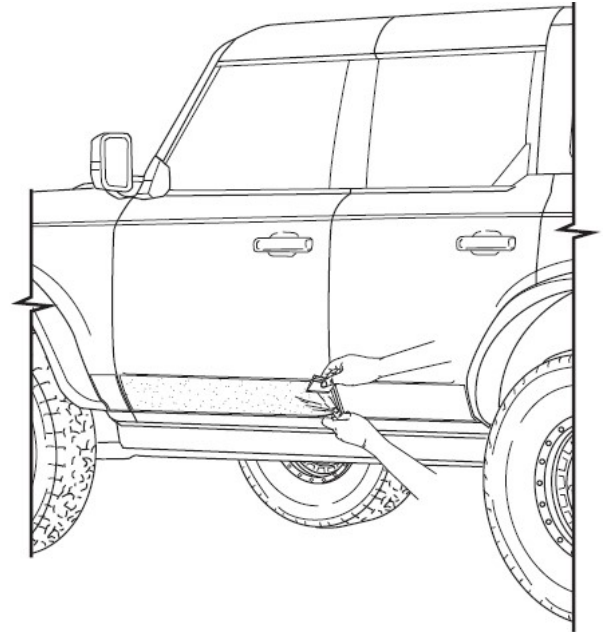
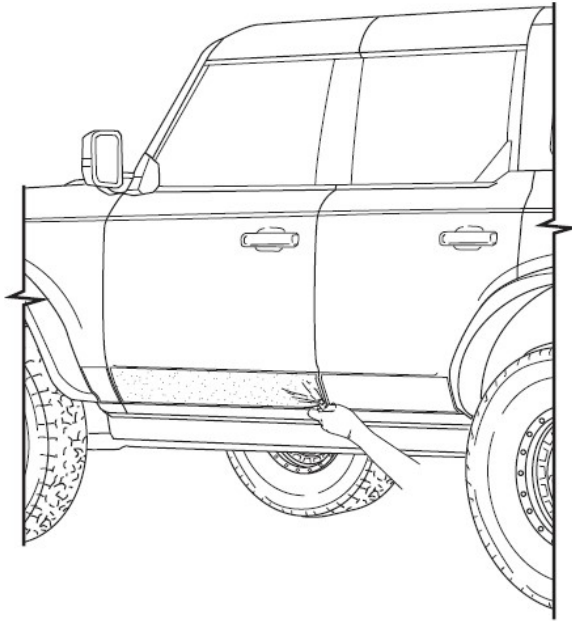

8

For “fingers” along the edges of the film, promptly spray the Tack solution into the finger and squeegee to the edge with a hard card wrapped with a Microfiber towel. The Microfiber towel helps with fingers along the edges by absorbing the tack solution as it is pushed out the edge of the film.

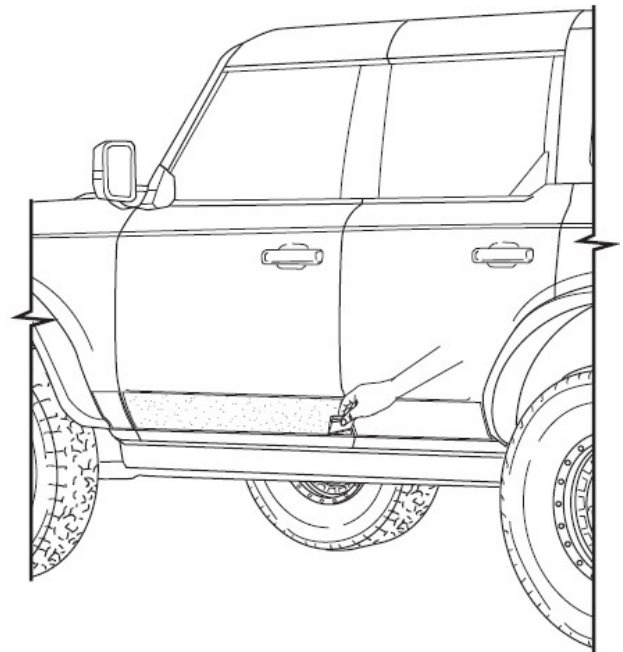
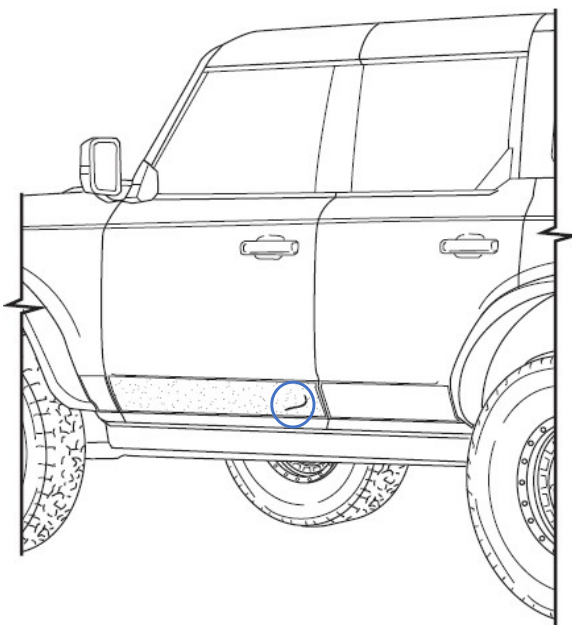

9

Dry the entire surface with a microfiber towel. Inspect for any debris under the film or trapped solution. The same process will be used for all parts be installed.

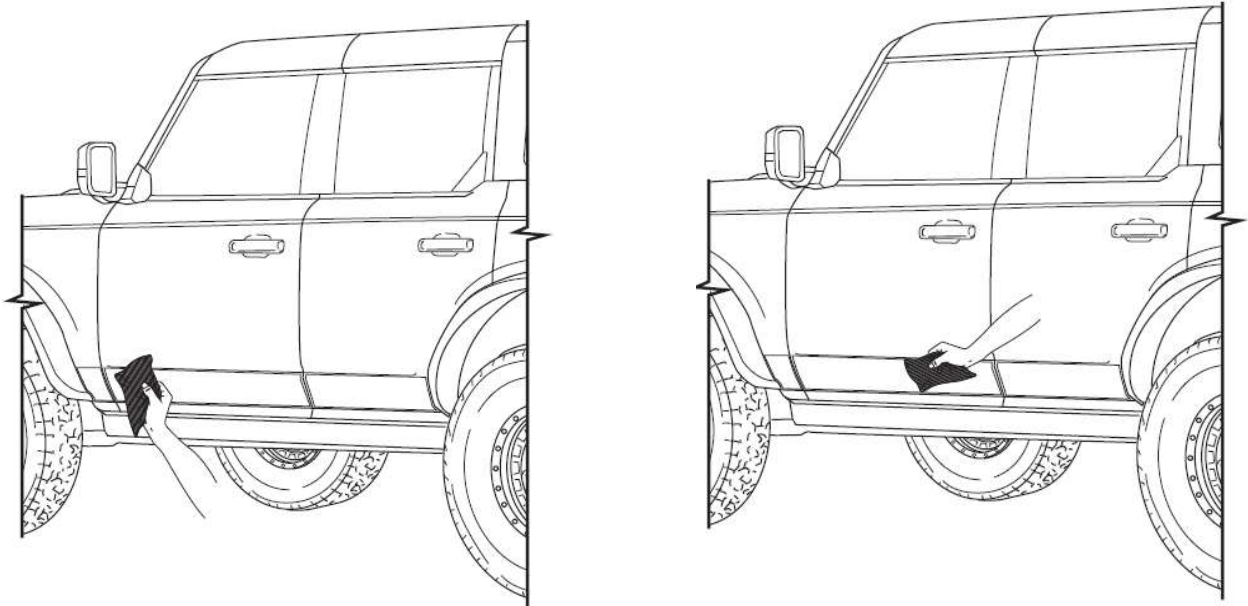

10

If you notice debris under the film, wet your fingers and gently lift the film from the closest edge and flush with mounting solution. Use your finger to remove the debris from the film. Once the debris is removed, re-wet the film and surface and squeegee the film back in place.



11

Wrap a microfiber towel around your finger and press the edge of the film. This will seal the edges preventing water, dirt ingress and prevent air pockets under the film. A heat gun on a low temperature setting and about 2 – 3” from PPF surface and a travel speed of about 2” - 3” of distance per second can be used to help dry and seal the edges preventing water or dirt ingress under the film.

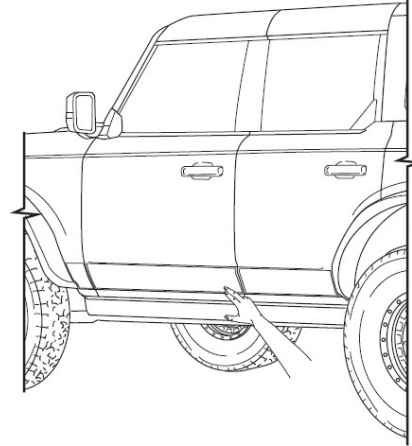

12

After application keep the vehicle indoors as follows:

- If the outside temperature is 60°F (15°C) and above: Is not required to keep it indoors.
- If the outside temperature is 40 to 59°F (4 to 15°C): Keep it indoors 1 hour at room temperature.
- If the outside temperature is below 40°F (4°C) : Keep it indoors 3 hours at room temperature.

13

Repeat this procedure for all patterns.

FILM REMOVAL

Paint protection film is best removed using a steamer or heat gun to soften the film adhesive. Slowly pull the film away from the vehicle at an angle less than 90°. Steam or heat the film along the lifting edge while continuing to pull the film from the surface. Any remaining adhesive can be removed using a mild adhesive remover.

3-YEAR LIMITED WARRANTY

The Paint Protection Film (PPF) is a robust product that effectively protects painted surfaces from damage as a result of stone impingement, mechanical or chemical abrasion, and other environmental factors. It has been designed to effectively resist scratching, scuffing and marring; however, it is not impervious to damage from these same factors and is susceptible to degradation over time. This is considered normal wear and tear.

For matters that are beyond this normal wear and tear, please contact the warranty team. This information is below.

CONTACT INFORMATION



Customer Service & Warranty

2875 St. Etienne Blvd

Windsor ON N8W 5B1

Canada

Phone: 519-944-3800 x.1367

Toll free: 1-800-739-6837

customer.service@gfxltd.com

www.gfxltd.com