



LOWER DOOR TRIM

Installation manual

Genuine SUBARU part numbers : E5510SL100 (turquoise blue)

E5510SL120 (silver)

Vehicle model :

FORESTER 2025MY~

To installation worker

This manual describes how to install and handle DOOR UNDERGARNISH.

1. Before installation, be sure to read this manual for proper work.
2. The caution mark  in this manual indicates important instructions. Strictly follow them.
3. SUBARU may not be held responsible for problems that occur due to your failure to follow this installation manual.

Important instructions

1. Before starting installation work, move the vehicle to a safe location.
2. To work safely, make sure that the vehicle does not move.
(Make sure to apply parking brake.)
3. After turning the ignition off, disconnect the battery ground terminal.
4. Handle this product with care not to damage it or the vehicle.

Rev. No.	Revision content	Date
△00	New establishment	2023/8/9

Completed installation sketch

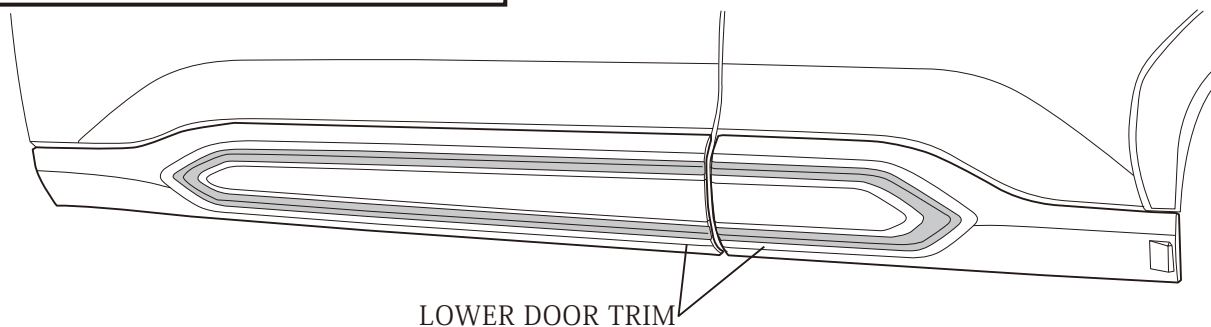

Component parts

■ E5510SL100 (turquoise blue) / E5510SL120 (silver)

No.	Item name	Qty
①	LOWER DOOR TRIM F RH	1
②	LOWER DOOR TRIM F LH	1
③	LOWER DOOR TRIM R RH	1
④	LOWER DOOR TRIM R LH	1

① : F RH ② : F LH



③ : R RH ④ : R LH

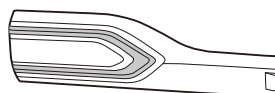

Spare parts No.	Installation position to the vehicle			
	Front RH	Front LH	Rear RH	Rear LH
Turquoise blue	E5517SL101	E5517SL102	E5517SL103	E5517SL104
Silver	E5517SL121	E5517SL122	E5517SL123	E5517SL124

※① to ④ Single items

Tools required for work



Gloves

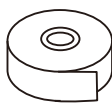

Protective tape

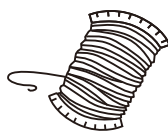

Nylon string



Cleaner
(Nonane is recommended.)



Hair dryer

Work outline

Replacement of LOWER DOOR TRIM

- ① Unpack the box and check that the product has no defect.
- ② Remove the door garnish. (Remove the front door garnish first.)
- ③ After that, clean the surface and make sure that there is no adhesive residue of the double-sided tape.
- ④ Install this product.
- ⑤ After completing the above, check the appearance to ensure there is no scratch and such.

Work procedures

1. Remove the door garnish.

- (1) Remove the front door garnish first.
- (2) To protect the surrounding area from scratch, apply protective tape.
- (3) When cutting the double-sided tape, heat the area on the garnish where double-sided tape is applied, by dryer for about 3 minutes to about 40 degrees Celsius.
- (4) Cut the double-sided tape with a nylon string.
- While pulling the garnish lower end toward the vehicle outside, peel off the vertical double-sided tape.
- (5) Remove the clip fitting portions.

⚠ Important instructions

- Remove the front door garnish first.
If you remove the rear door garnish first, it may interfere with the front door garnish.
- When heating the door garnish, be careful not to burn yourself.
- When cutting and removing the double-sided tape, be careful not to damage the vehicle.

Front door garnish

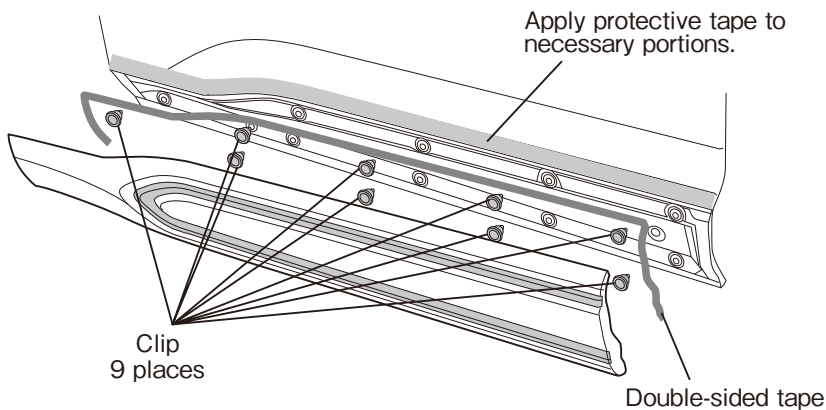

Remove the front door garnish.

- ① While pulling the door rear lower end toward outside, remove the vertical double-sided tape.
※ When cutting the double-sided tape, use a nylon string if needed.
- ② Remove the clips from the back to the front, while pulling the garnish lower end toward the vehicle outside.
- ③ After removing the lower clips, remove the front vertical clip and then the upper clips.

Rear door garnish

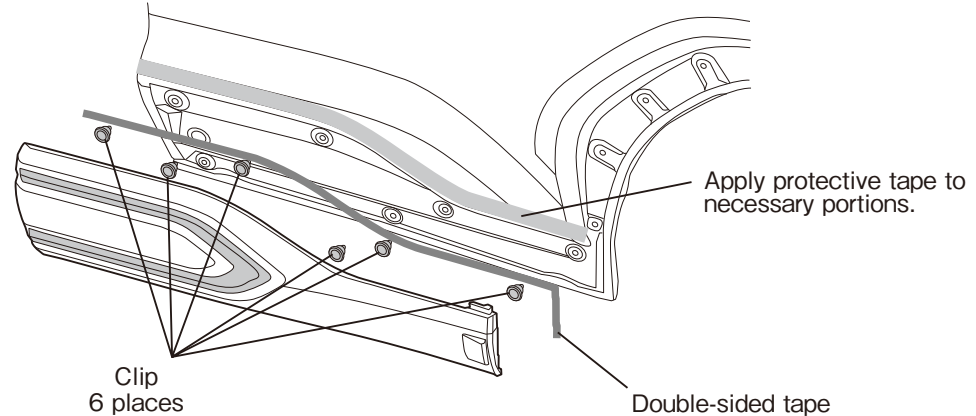

Key points to remove the rear LOWER DOOR TRIM

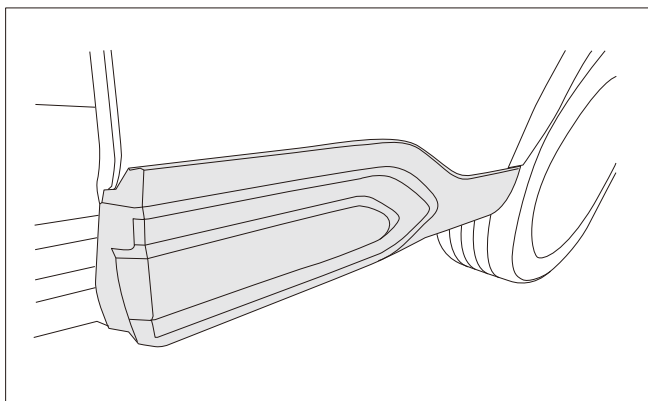

For your reference
Remove the front door garnish first.
If you remove the rear door garnish first, it may interfere with the front door garnish.

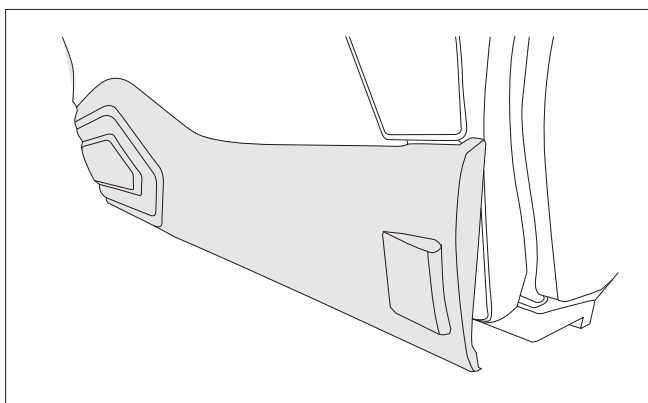

① Hold and pull the garnish lower end toward outside.
Remove the clips on the lower side center, and then on the front side.

② Remove the garnish while peeling off the vertical double-sided tape on the vehicle rear side.
Remove the garnish with care using a nylon string if needed.

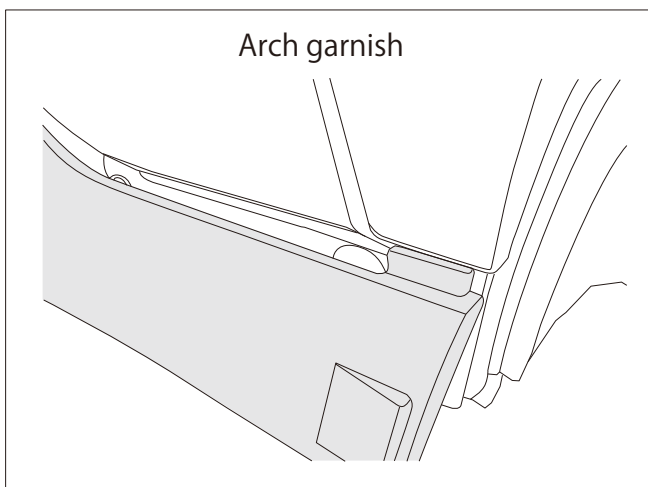

③ Remove other clips and double-sided tape.
Pull the garnish downward, while paying attention to the LOWER DOOR TRIM inserted to the arch garnish lower end.

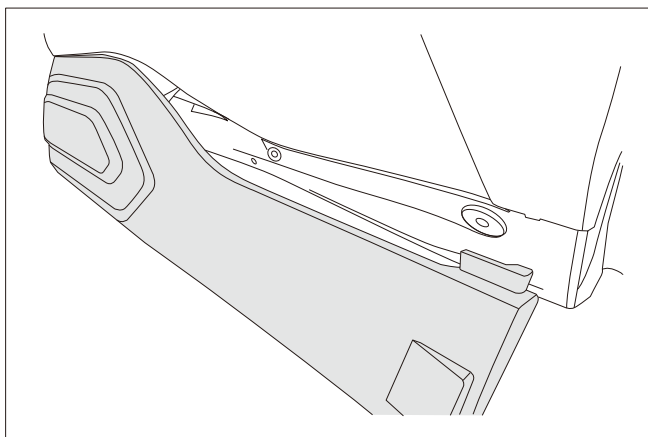

④ Remove the LOWER DOOR TRIM.
After that, make sure to peel off the remaining double-sided tape.

2. Install the LOWER DOOR TRIM.

- (1) Remove the remaining double-sided tape on the door panels, clean and degrease the adhesive surface.
- (2) Install the rear garnish first.
- (3) Heat the door panel adhesive surface to about 40 degrees Celsius.
(Use a hair dryer.)
- (4) Holding the blue pick-up tape, peel off all the release paper of the double-sided tape. Install the clips to the door panel clip holes.
When installing the rear undergarnish, align with (insert into) the arch garnish lower end.
- (5) After the installation, press and fit the double-sided tape.

⚠ Important instructions

- Dirty adhesive surface could cause adhesion failure. Make sure to clean and degrease the surface.
- Install the rear garnish first. Otherwise, the front garnish and the rear garnish may interfere with each other.
When installing the rear garnish, align it with the arch garnish first.
- Make sure to press and fit the double-sided tape firmly. (Press it for about 10 seconds with a force of 50 N (the degree to shake the vehicle) .

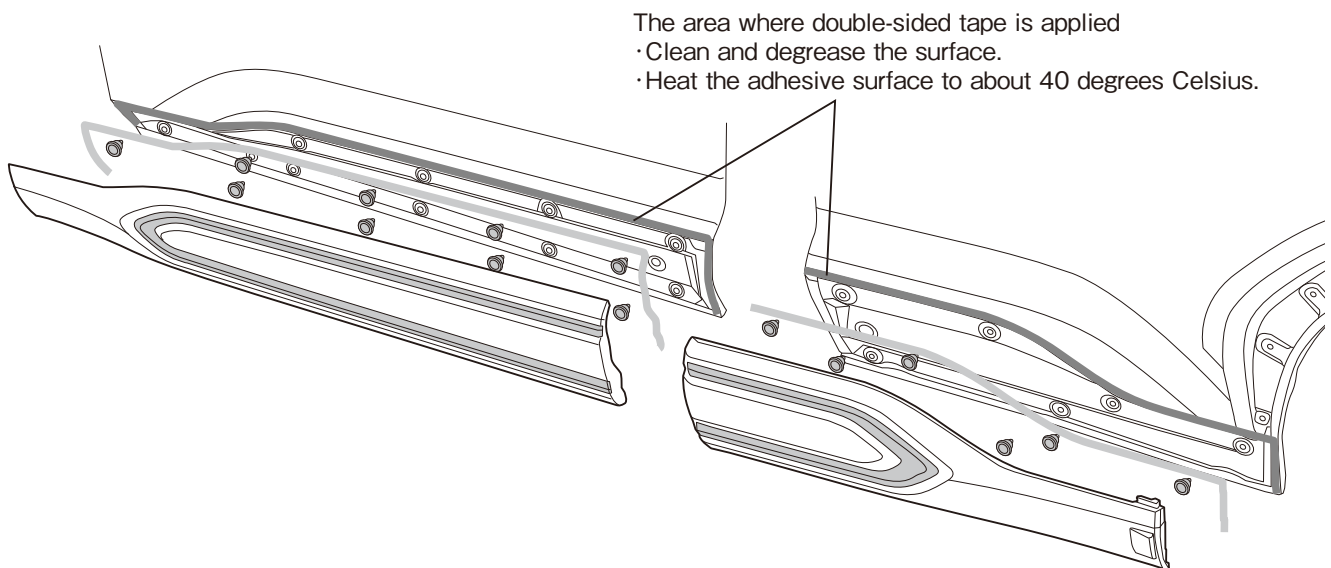

3. Check after work completion

- (1) Check that there is no scratch on this product or surrounding areas, and that this product is surely installed.
- (2) Return the replaced parts to the customer.
This is the completion of the LOWER DOOR TRIM installation.