

Front Brake Package Installation (Instruction ID: 84536751)

Installation Instructions Part Number

84536751

Light Duty Truck & SUV 5JL 6-Piston Performance Front Brake Kit

Kit Contents

Qty	Description
1	Performance front brake kit
1	LH, front 6-piston loaded caliper*
1	RH, front 6-piston loaded caliper*
2	Front 1-piece 410x32 mm rotor*
4	Front caliper mounting bolts
4	Brake Hose Gaskets
2	Brake hose fitting bolt, fine thread
1	LH, Brake Hose
1	RH, Brake Hose
1	LH, Splash Shield
1	RH, Splash Shield
2	Splash Shield Closeout
4	Nut (Splash Shield)
4	Hub Seal
1	Spare Tire Caution Hang Tag
1	Installation Instructions

Note: *Denotes parts are serviceable, check Electronic Parts Catalog for availability.

This kit includes a calibration update for the Electronic Brake Control Module

This kit includes a calibration update for the Electronic Brake Control Module. Reprogramming must be done with a Service Programming System (SPS) at an Authorized GM Dealer. Before performing programming via SPS, the GM dealer must contact the Techline Customer Support Center (TCSC) 1-800-828-6860 (English) or 1-800-503-3222 (French Canadian) to have the appropriate calibration applied to the VIN. The vehicle VIN and Authorization Code (included in the accessory packaging) must be provided to TCSC to obtain the accessory calibration changes.

Note: The cost of re-programming and reconfiguring is included in the cost of this kit.

Note: The dealer is instructed to charge the calibration and configuration to Labor Code 0602898 at an allowable 0.3 hrs.

Tools Required

CH-43631 Ball Joint Separator

Equivalent regional tools: [Special Tools](#).

Procedure

Front Brake Caliper and Rotor Removal

Warning: Refer to [Brake Dust Warning](#).

Warning: Refer to [Brake Fluid Irritant Warning](#).

Caution: Refer to [Brake Fluid Effects on Paint and Electrical Components Caution](#).

Note: Do not loosen or remove the upper control arm to install the brake kit.

1. Inspect the fluid level in the brake master cylinder reservoir.
2. If the brake fluid level is midway between the maximum full point and the minimum allowable level, no brake fluid needs to be removed from the reservoir before proceeding.
3. If the brake fluid level is higher than midway between the maximum full point and the minimum allowable level, remove brake fluid to the midway point before proceeding.

Warning: Failure to disconnect the battery terminal before proceeding may cause issues and Check Engine Lights.

4. Disconnect the negative battery cable. Refer to [Battery Negative Cable Disconnection and Connection](#) in Vehicle Service Manual.
5. Raise and support the vehicle. Refer to [Lifting and Jacking the Vehicle](#) in Vehicle Service Manual.
6. Remove the front tire and wheel assembly. Refer to [Tire and Wheel Removal and Installation](#) in Vehicle Service Manual.

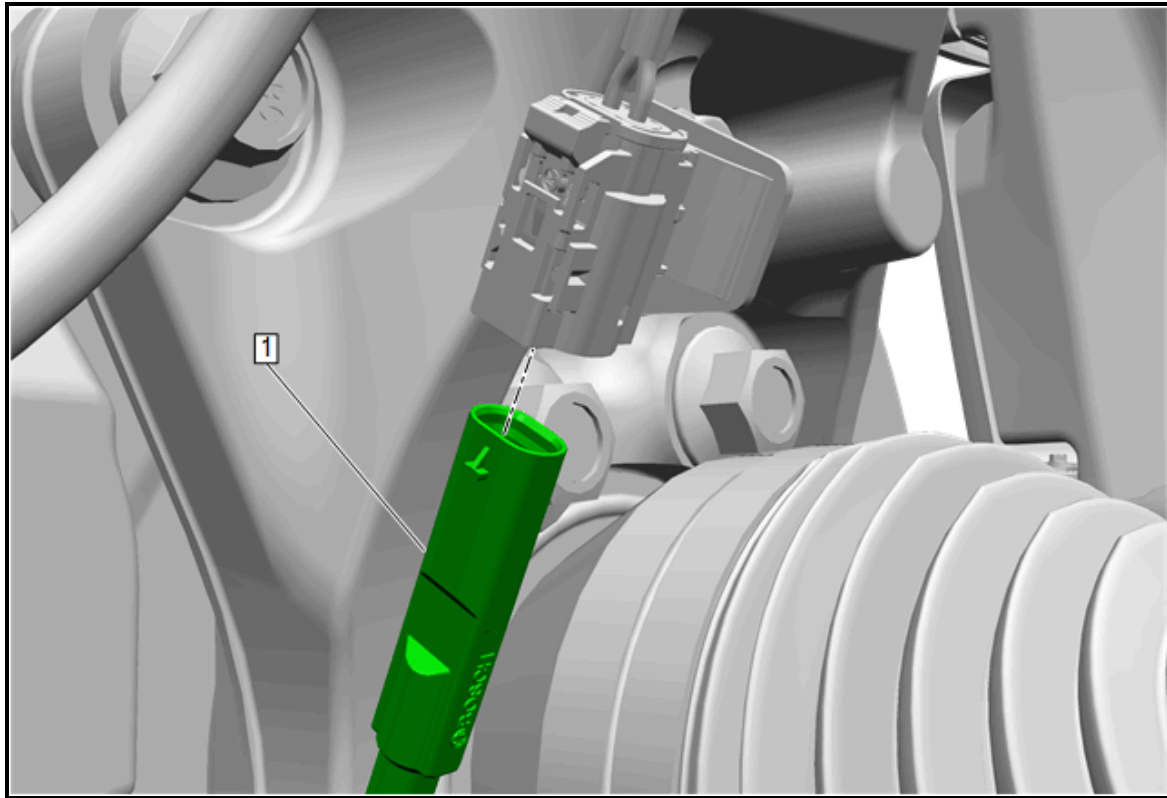

Note: This step applies only to the left front brake side only.

7. Disconnect the brake pad wear sensor connector (1) from the brake pad wear sensor harness.
8. Install a C-clamp against the outer brake pad and the rear of the brake caliper body.
9. Slowly tighten the C-clamp until the brake caliper piston is compressed into the brake caliper bores.

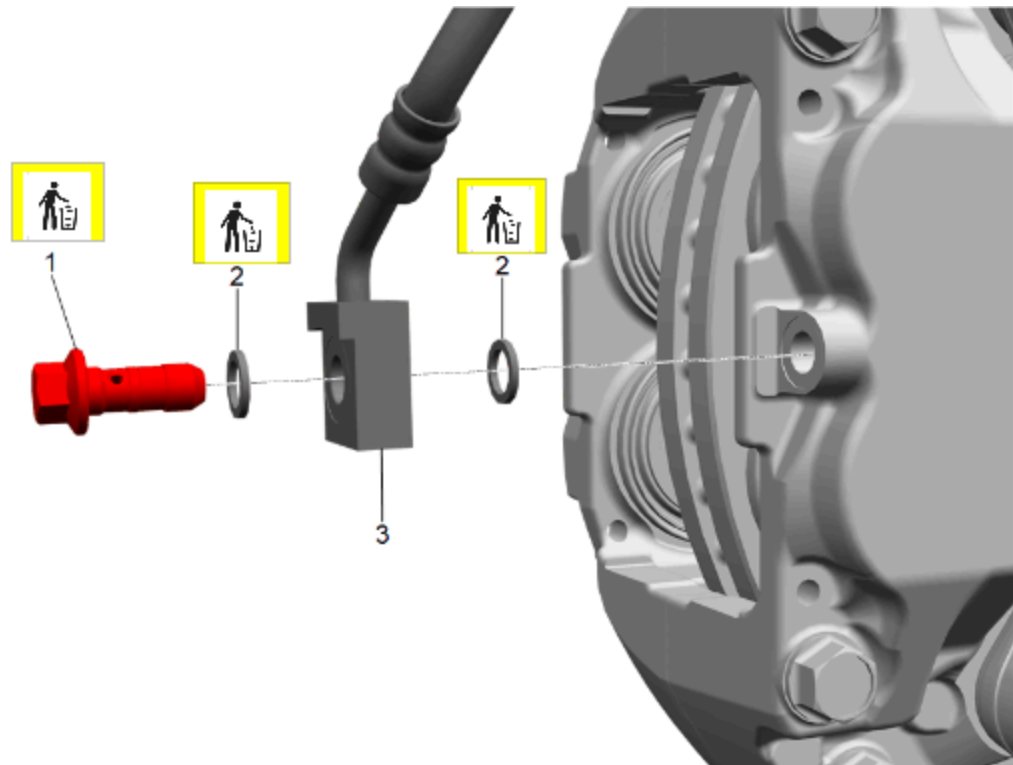

10. Front brake hose fitting bolt (1) » Remove and DISCARD [1x].

Note: This brake hose fitting bolt is NOT compatible with the new calipers!!! Discard the bolt and use the new one provided in the kit.

11. Front brake washer (2) » Remove and DISCARD [2x].

12. Front brake hose (3) @ front brake caliper » Remove.

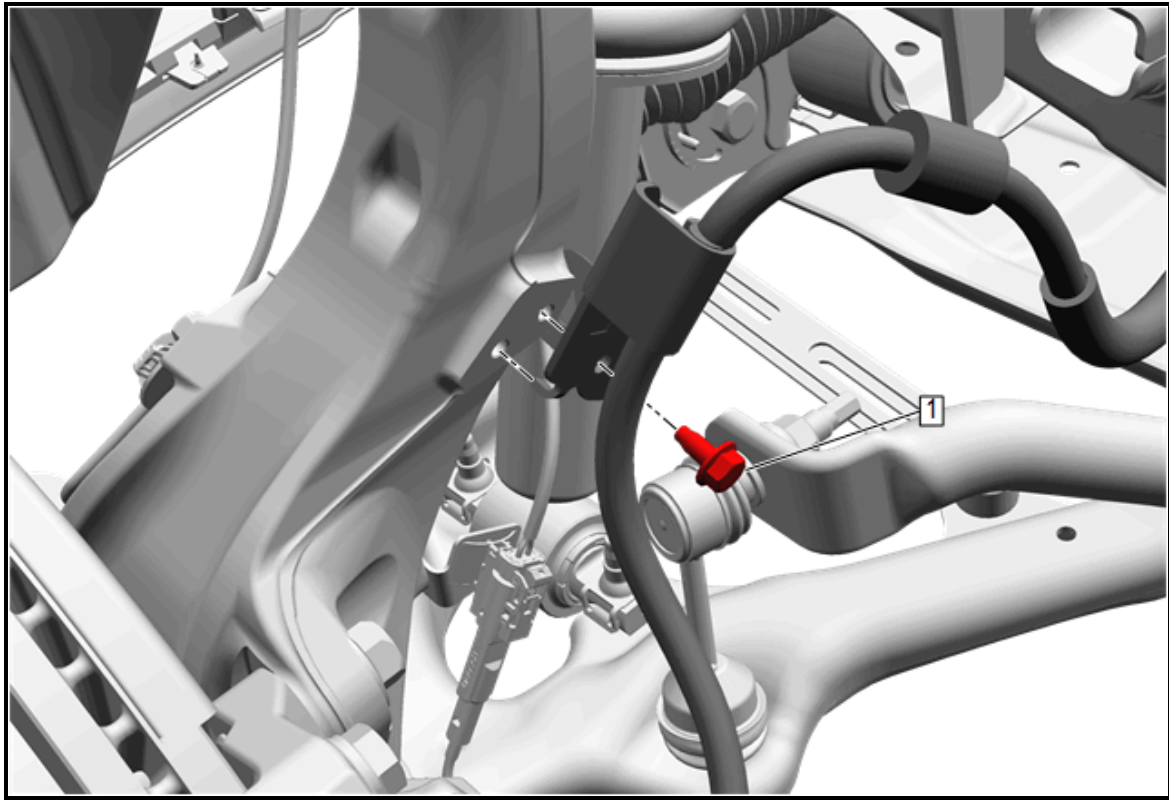

13. Remove the front brake hose bracket bolt (1).

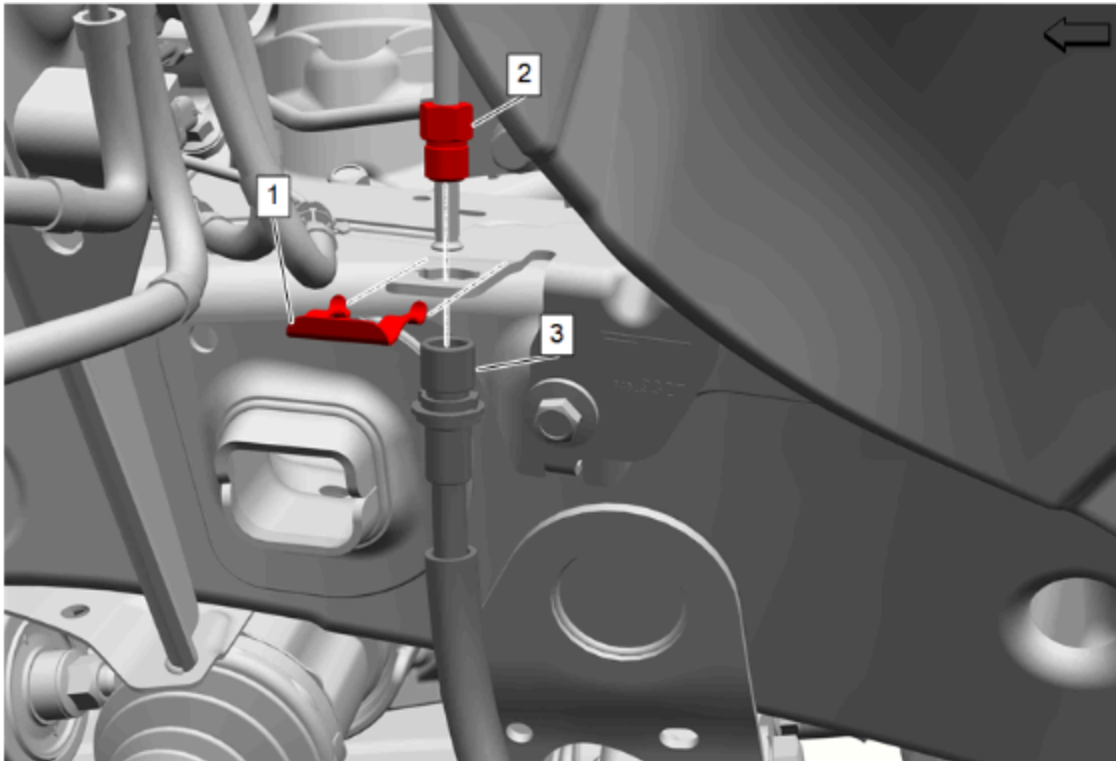

14. Remove the front brake front pipe nut (2) .

15. Remove front brake hose clip (1) .
16. Front brake hose (3) » Remove and DISCARD [1x].
17. Cap the brake pipe fitting to prevent brake fluid loss and contamination.

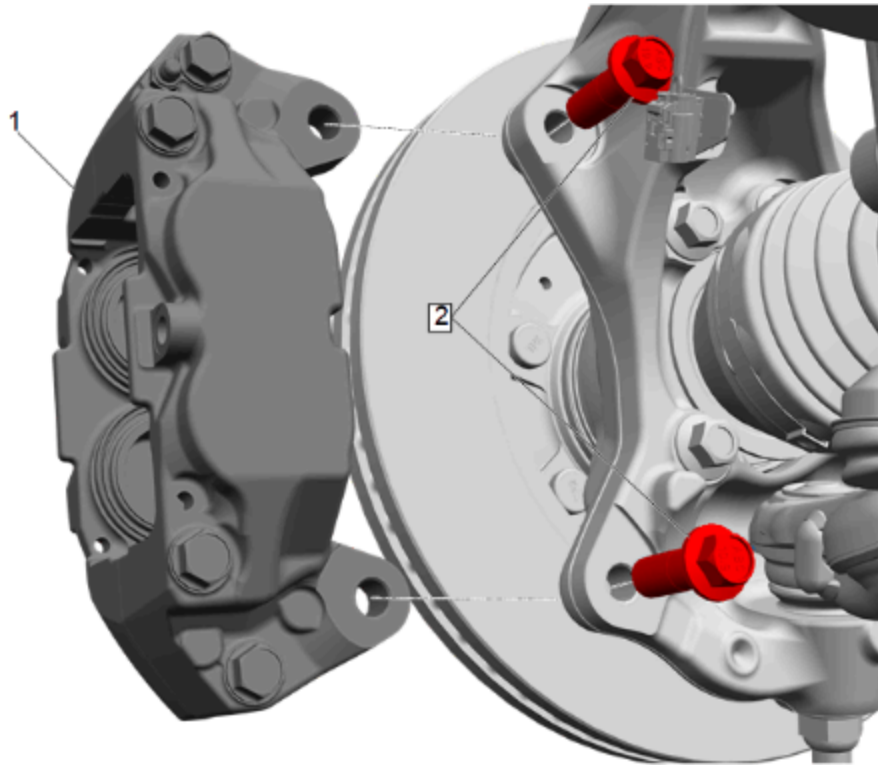

18. Remove the brake caliper bracket bolts (2).
19. Remove the brake caliper and bracket assembly (1) from the knuckle.

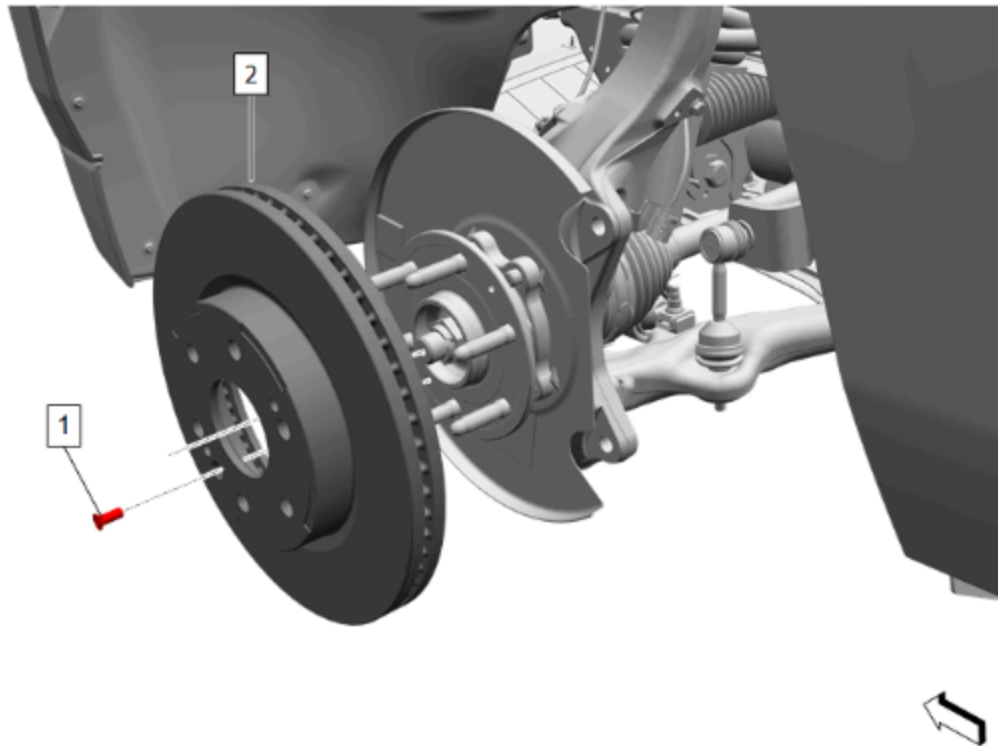

20. Remove the brake rotor bolt (1). Do not discard the bolt.
21. Remove the brake rotor (2).
22. If the brake rotor will not separate from the wheel hub, perform the following:
 - 22.1. Clean the brake rotor mating surface and the threaded holes in the brake rotor hub face of any accumulated corrosion.
 - 22.2. Apply a generous amount of commercially available penetrating oil or equivalent to the brake rotor mating surface, especially around the wheel stud holes and threaded holes in the brake rotor hub face.
 - 22.3. Install 2 M10x1.5 bolts into the threaded holes in the brake rotor hub face.
 - 22.4. Slowly and evenly tighten the M10x1.5 bolts to force the brake rotor from the wheel hub and bearing.
23. Using a stiff wire brush, clean any accumulated debris and corrosion from the mating surfaces of the wheel hub and brake rotor.
24. Remove any burrs or raised metal that may have been created by the M10x1.5 forcing bolts.

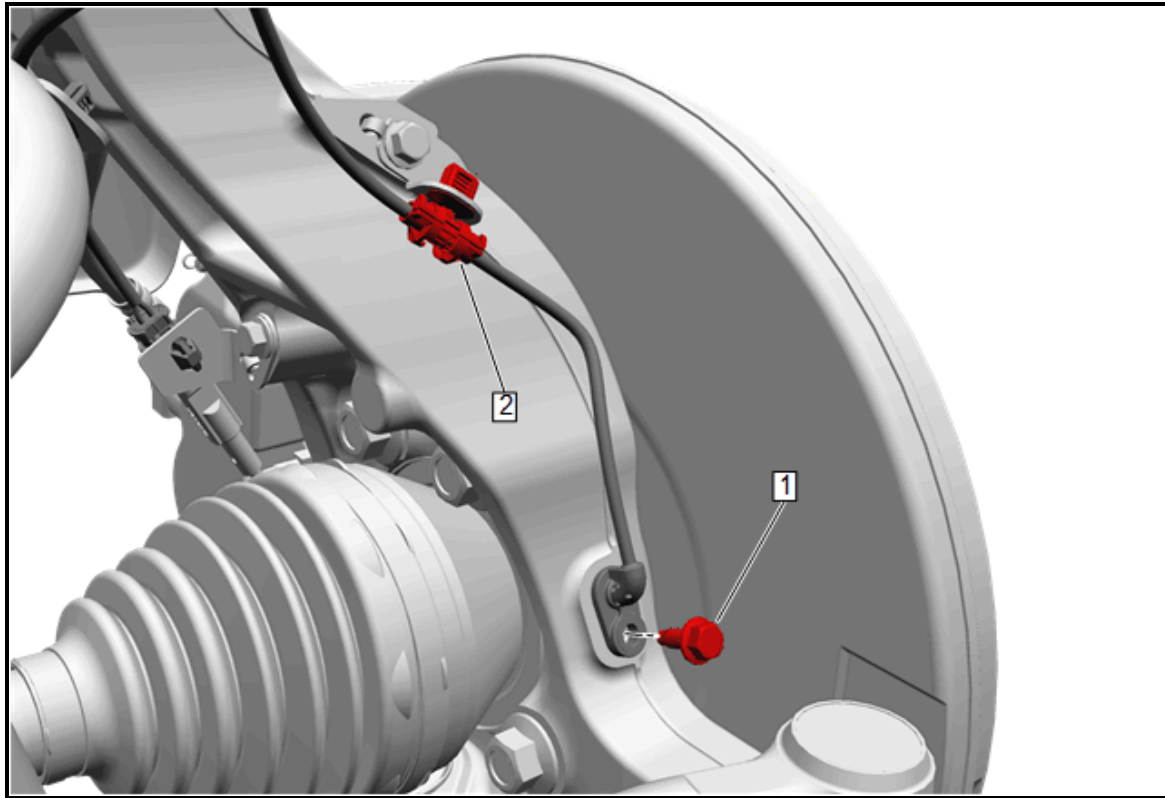

25. Remove the front wheel speed sensor bolt (1). Do not discard.
26. Remove the wheel speed sensor (2) from the knuckle. Move the sensor out of the way so that it is not damaged.

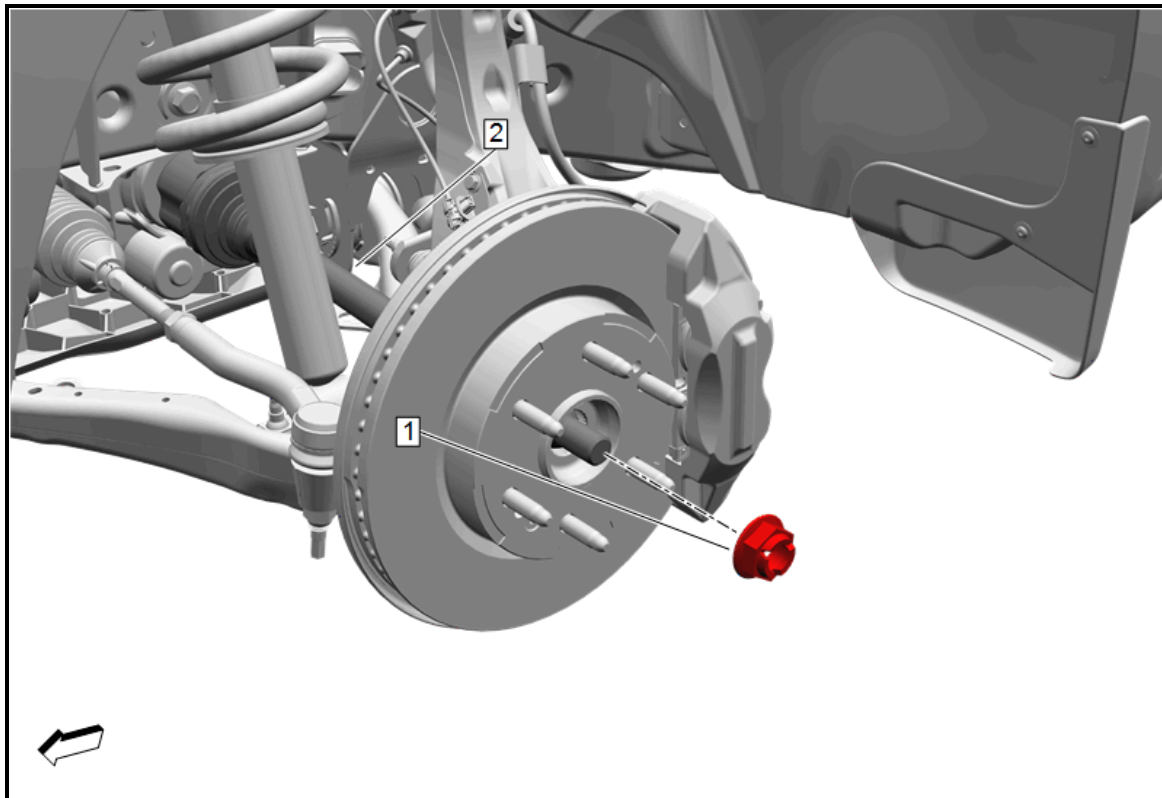

© 2025 General Motors. All rights reserved.

27. On a 4WD truck, remove the axle shaft nut (4). Do not use air tools to remove the nut as the threads may be damaged. Hand tools only. Do not discard the nut.

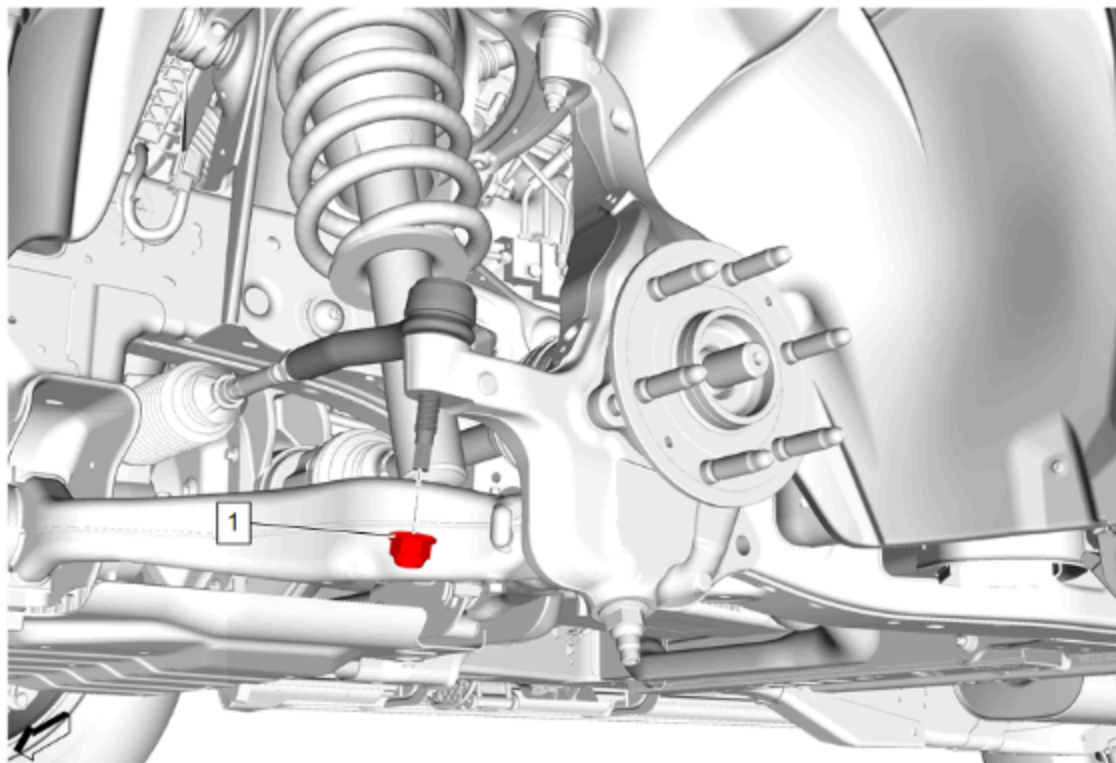

28. Remove the steering linkage outer tie rod nut (1).

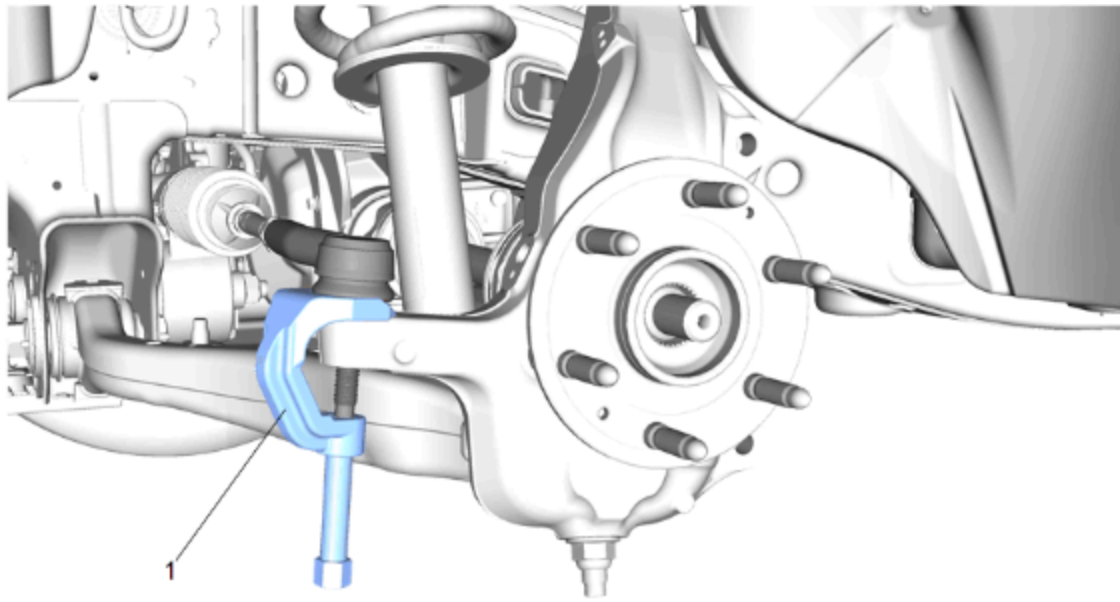

Note: Do not loosen or remove the upper control arm to install the brake kit.

Caution: Do not attempt to disconnect a steering linkage joint by driving a wedge between the joint and the attached part. Seal damage may result which will cause premature failure of the joint.

29. Using *CH-43631* Ball Joint Separator (1), remove the steering linkage outer tie rod from the steering knuckle.

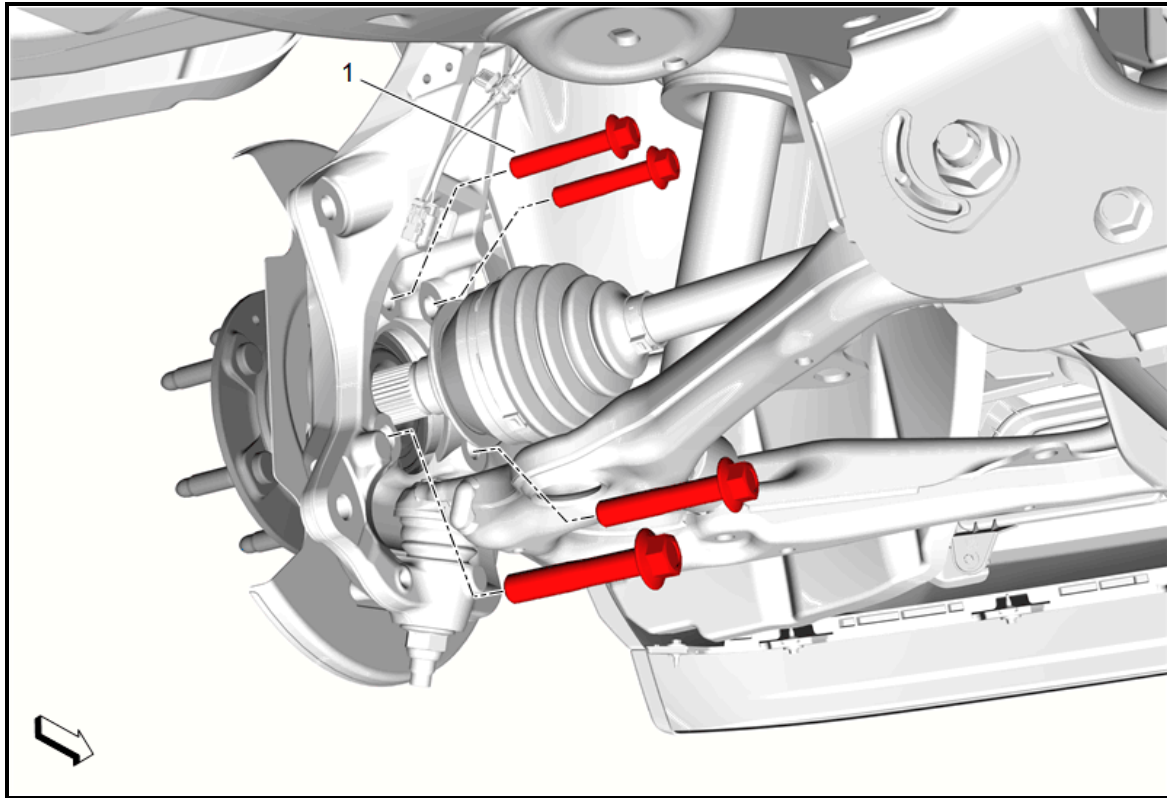

© 2025 General Motors. All rights reserved.

30. Reposition the front wheel drive half shaft as necessary to access the front wheel hub bolts (1).
31. Remove the four hub and bearing mounting bolts (1). Be careful not to damage the axle shaft boot on 4WD trucks. Do not discard the bolts.

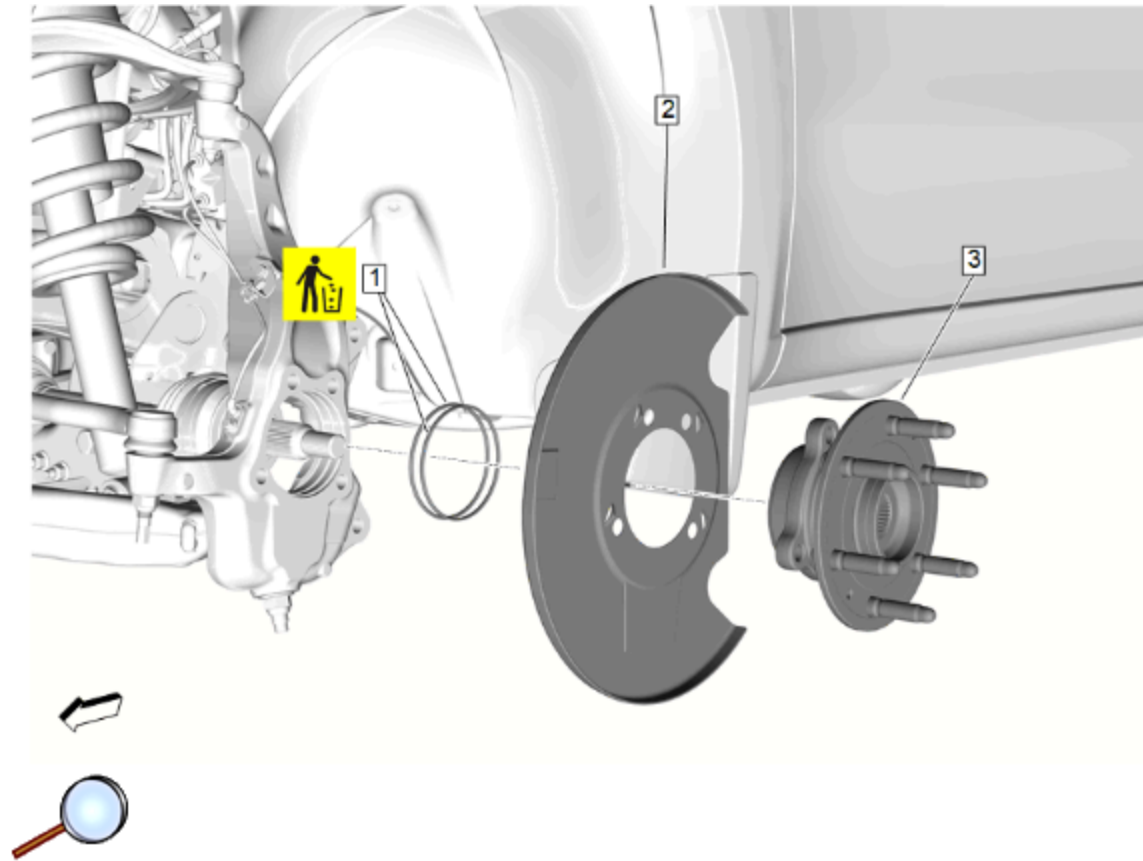

32. Using a hub and bearing pulling tool, remove the hub and bearing (3) from the knuckle. Do not discard the hub and bearing. Remove the splash shield (2) and discard. Remove the front wheel hub seals (1) and discard.

Performance Front Rotor, Caliper and Hose Installation

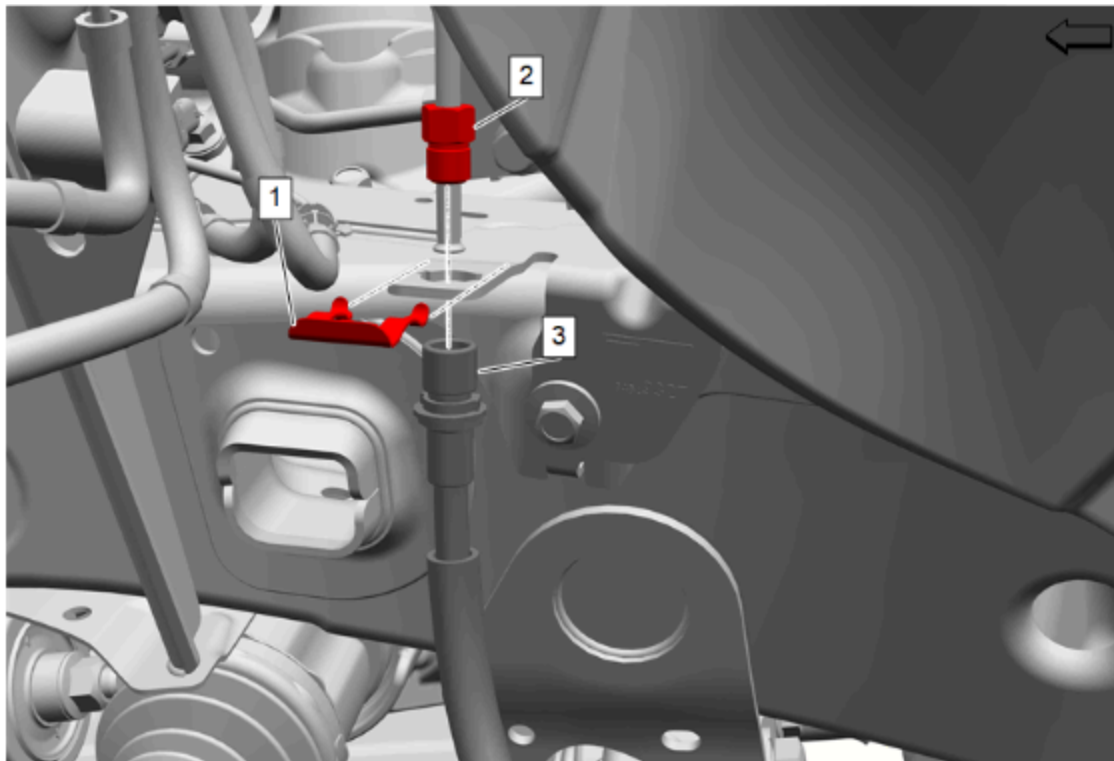

Caution: Use the correct fastener in the correct location. Replacement fasteners must be the correct part number for that application. Fasteners requiring replacement or fasteners requiring the use of thread locking compound or sealant are identified in the service procedure. Do not use paints, lubricants, or corrosion inhibitors on fasteners or fastener joint surfaces unless specified. These coatings affect fastener torque and joint clamping force and may damage the fastener. Use the correct tightening sequence and specifications when installing fasteners in order to avoid damage to parts and systems.

1. Remove the cap from the front brake front pipe outlet.
2. Install the front brake hose (3).
3. Install the front brake hose clip (1).
4. Install and tighten the front brake front pipe nut (2) to 25 N.m (18 lb ft).

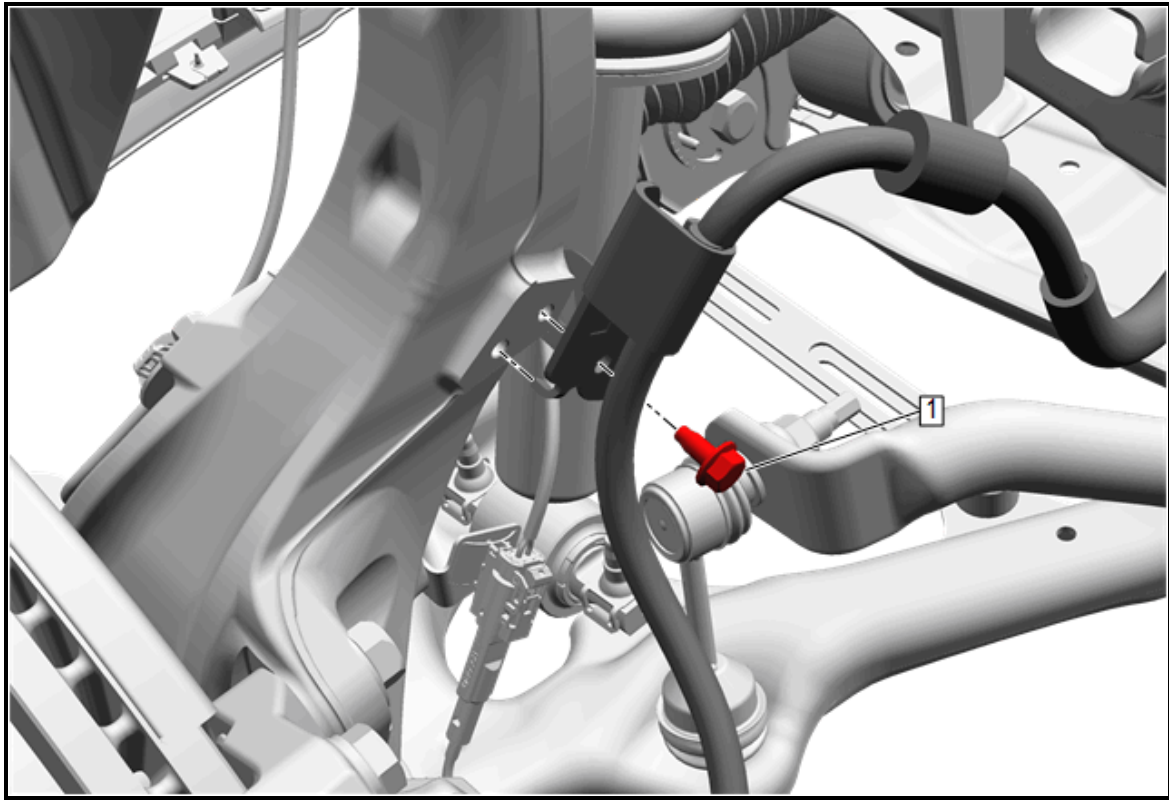

5. Install the front brake hose bracket bolt (1) and tighten to 9 N.m (80 lb in).

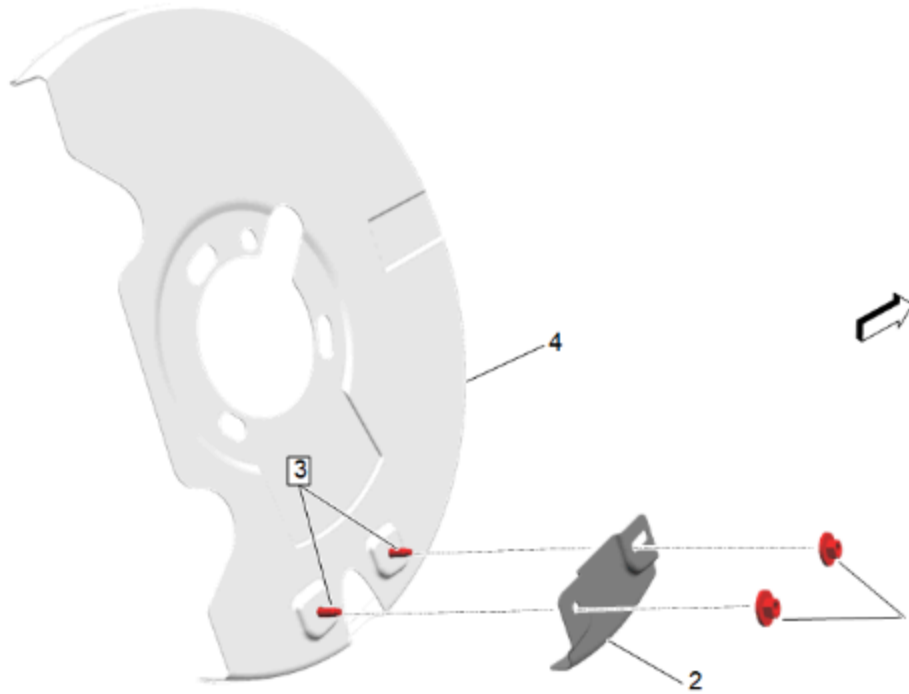

6. Install the closeout shield (2) over the studs (3) on to the splash shield (4). Install the nuts (1) on to the studs (3) and tighten to 9 N.m (80 in lb).

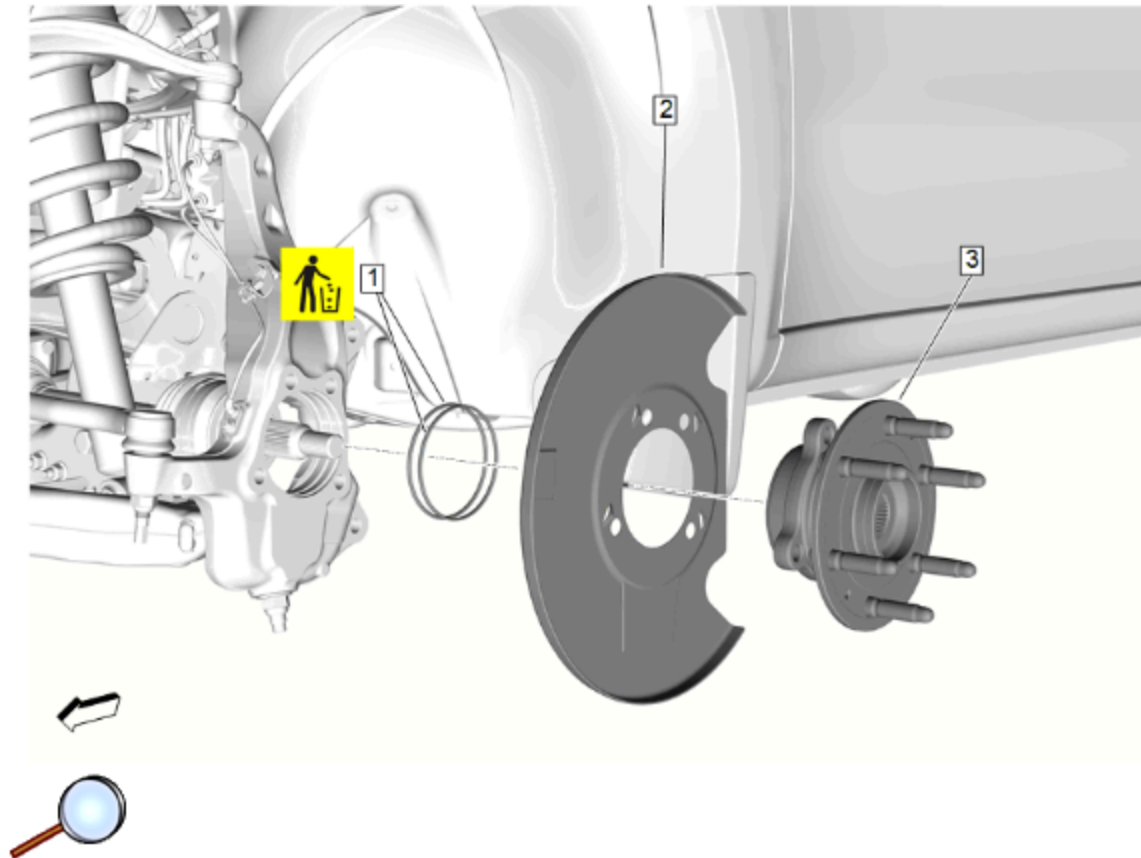

7. Clean any debris and corrosion from the steering knuckle bearing pilot bore.
8. Apply a thin coating of grease evenly ensuring complete coverage of the steering knuckle pilot bore only.
9. Apply the new front wheel hub seals (1) on to the hub (3). Ensure that the seals are properly seated in the grooves of the steering knuckle.
10. Install the new splash shield (2) and hub and bearing (3) to the knuckle. On a 4WD truck, make sure the axle shaft splines are lined up with the splines in the hub and bearing.

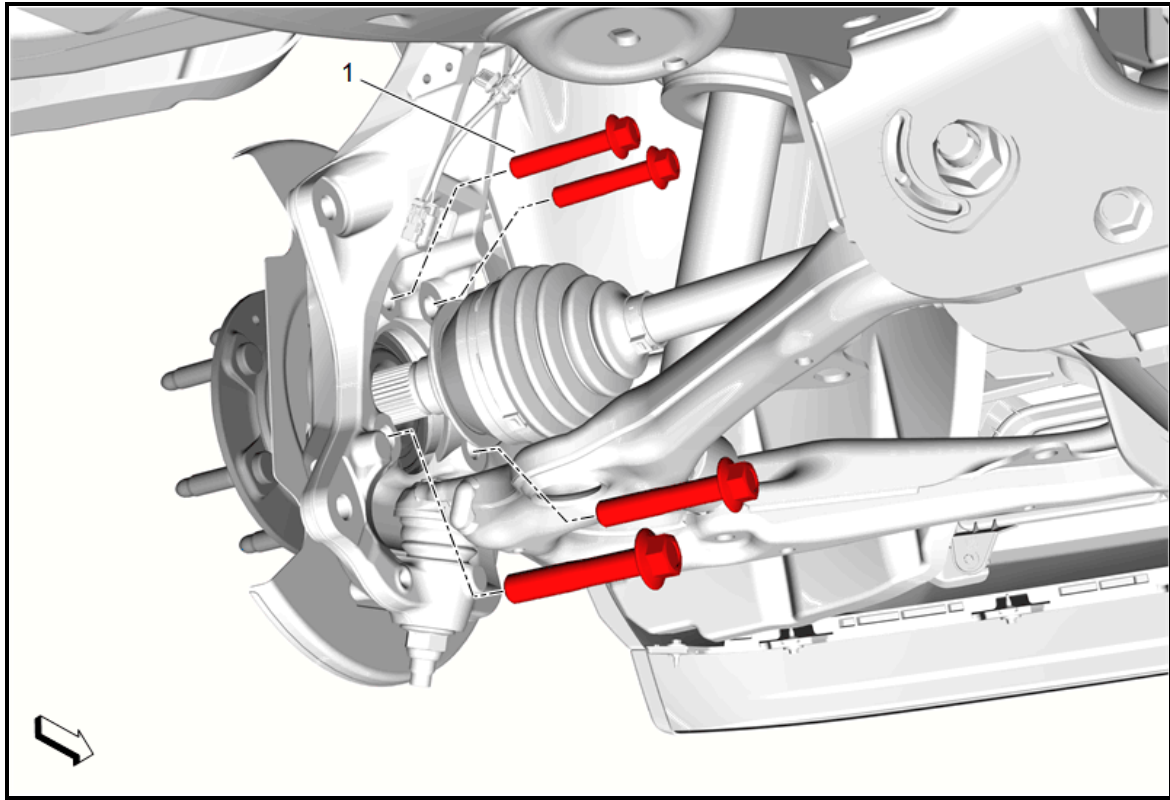

11. Reposition the front wheel drive half shaft as necessary and install the four hub and bearing mounting bolts (1) and torque to 150 Nm +30 to 45 Degrees (110 lb ft +30 to 45 Degrees).

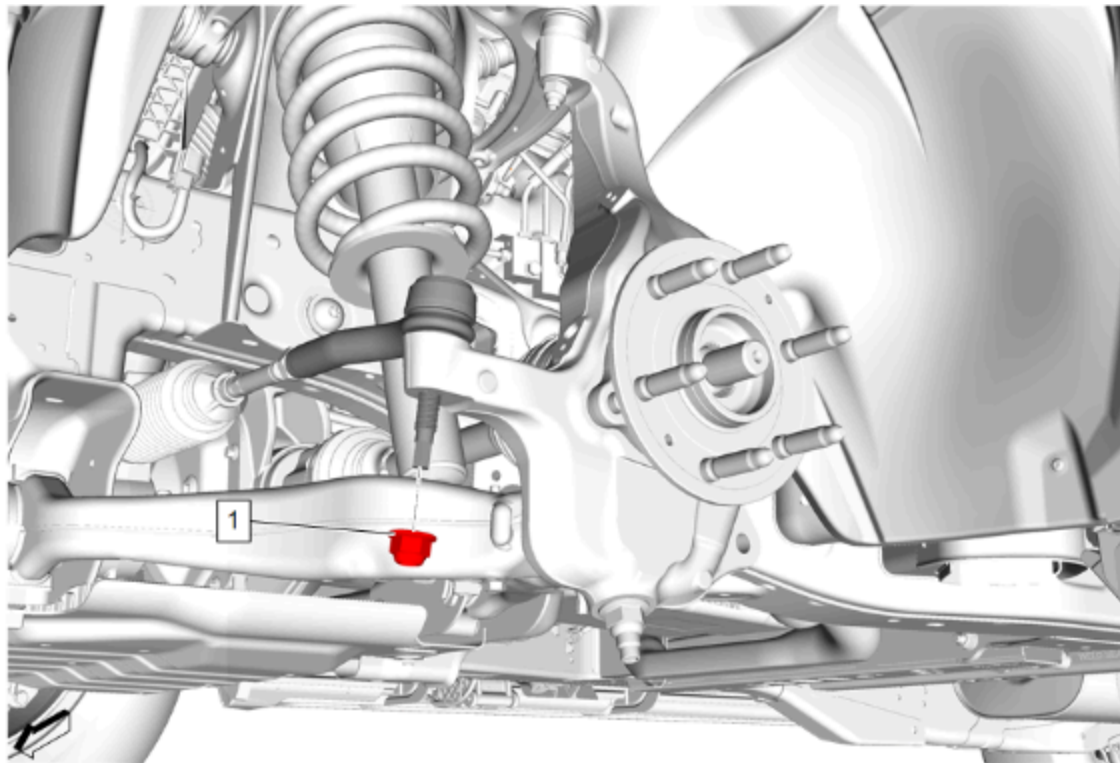

12. Install the Steering Linkage Outer Tie Rod Nut (1) and torque to 35 N.m (26 ft lb) plus 85 to 100 Degrees.

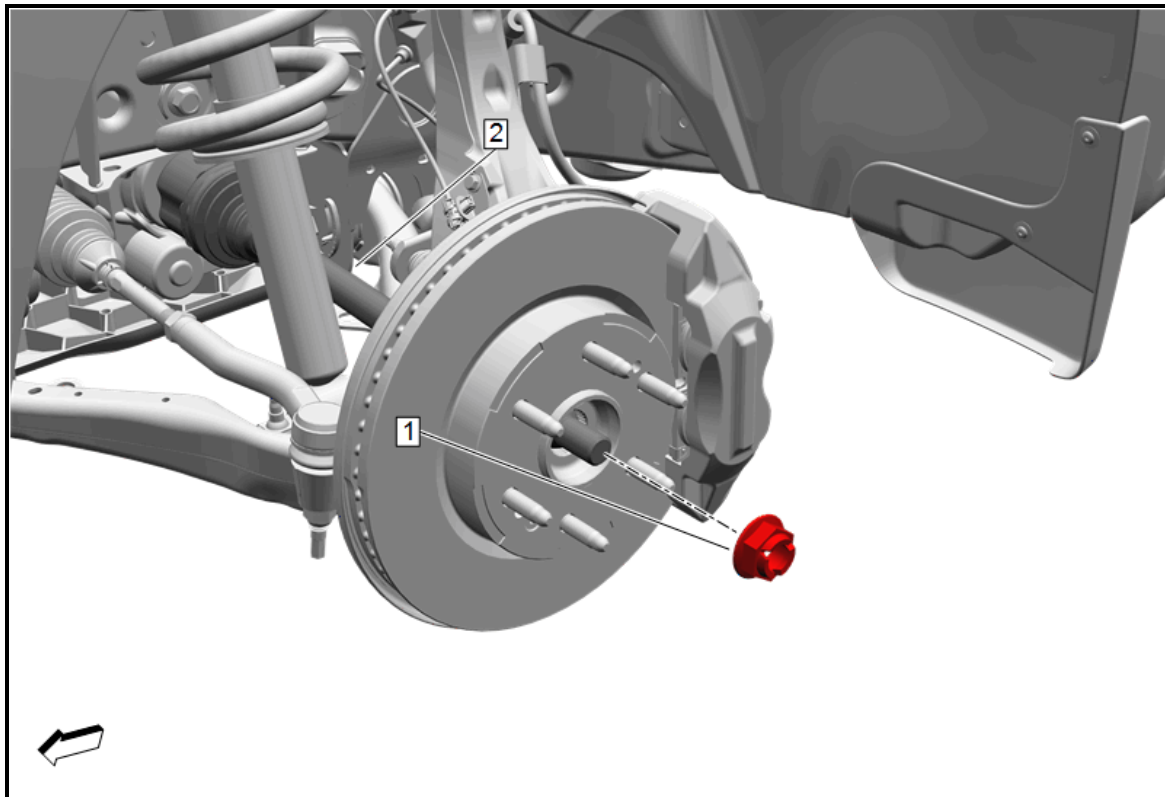

© 2025 General Motors. All rights reserved.

13. On 4WD trucks, reinstall the axle shaft nut (1) and torque to 250+/-20Nm (185 ft lb +/- 14 ft lb).

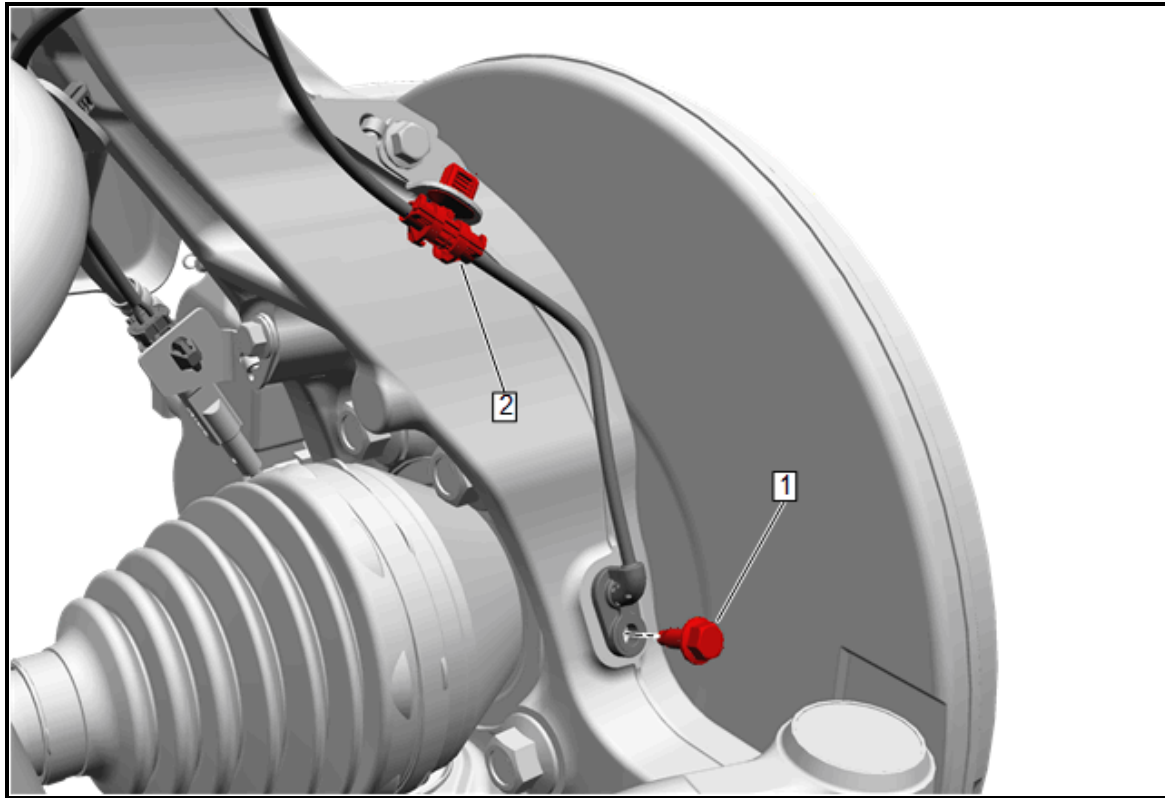

14. Reinstall the wheel speed sensor (2) and the retainer bolt (1). Torque to 9 N.m (80 lb in).

Note: Whenever the brake rotor has been separated from the hub/axle flange, any rust or contaminants should be cleaned from the hub/axle flange and the brake rotor mating surfaces. Failure to do this may result in excessive assembled lateral runout (LRO) of the brake rotor, which could lead to brake pulsation.

15. Thoroughly clean any rust or corrosion from the mating surface of the hub/axle flange.

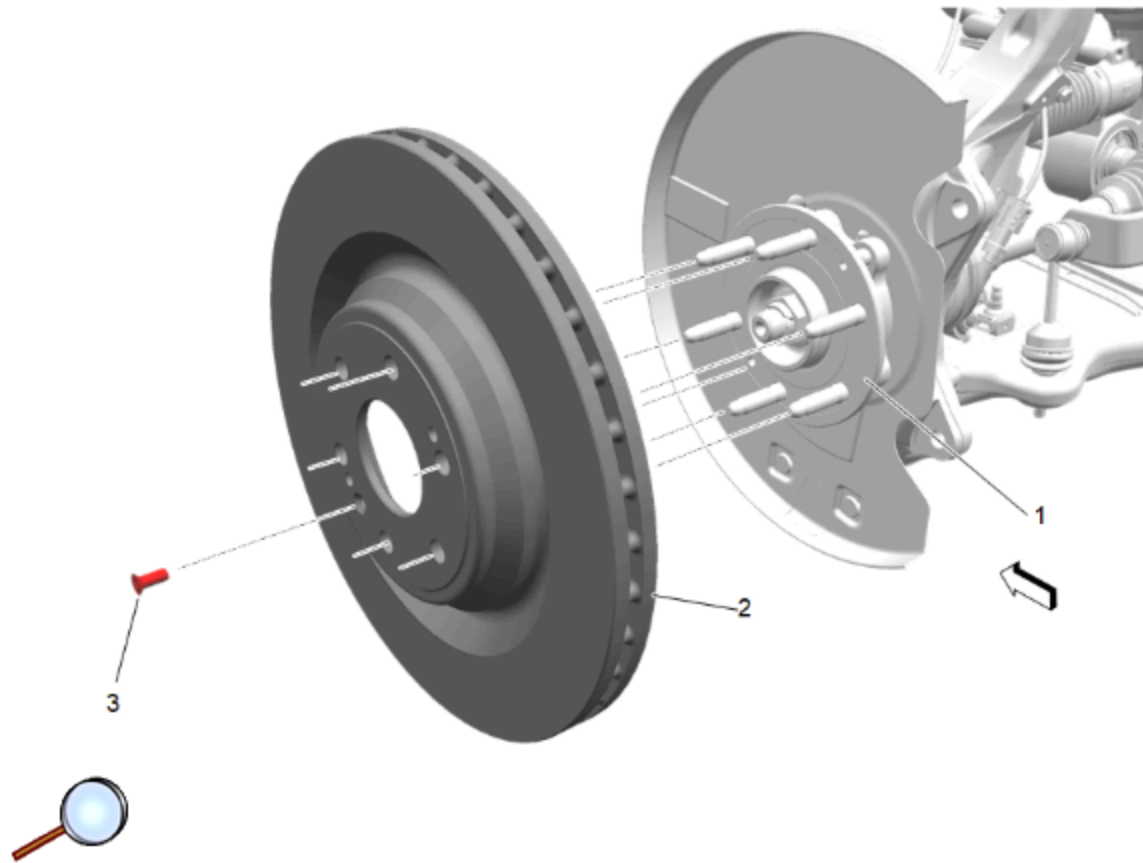

16. Install the new brake rotor (2), with previously retained brake rotor bolt (3) to hub and bearing (1) and tighten to 22 N.m (16 lb ft).

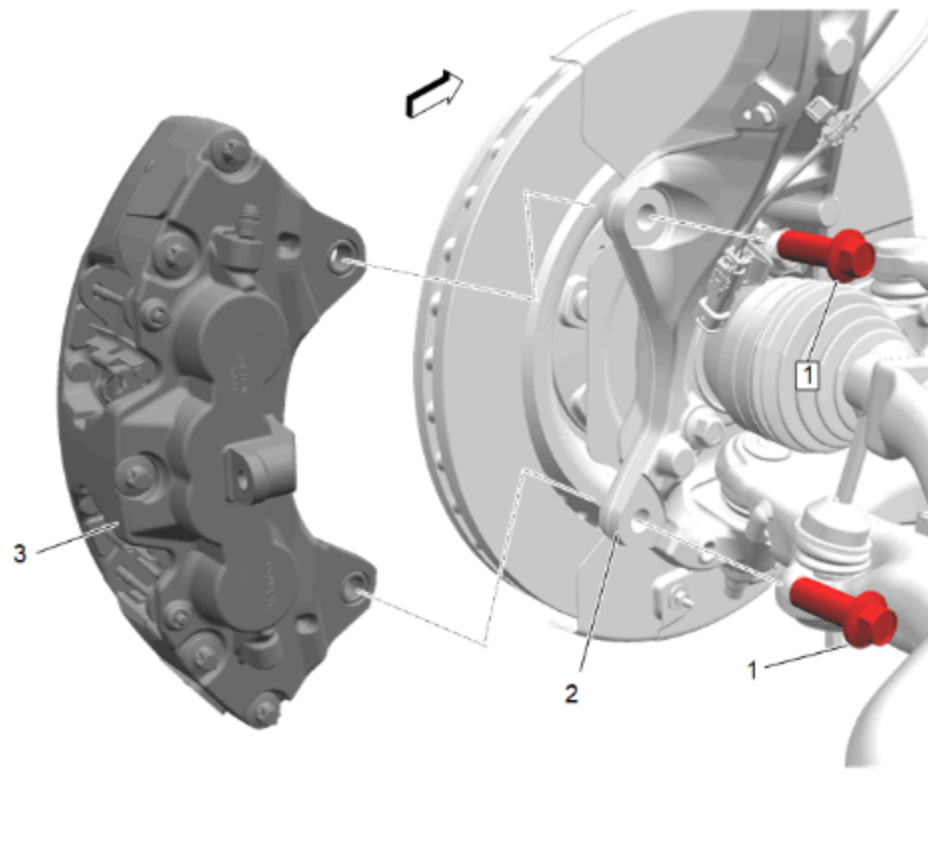

17. Install the brake caliper (3) to the steering knuckle (2).

18. Install the brake caliper bolts (1) and tighten to 50 N.m +30 to 45 Degrees (37 lb ft+30 to 45 Degrees). Use the new caliper bolts provided in the kit. These bolts have a dry thread locker patch applied. Additional thread locker is not required.

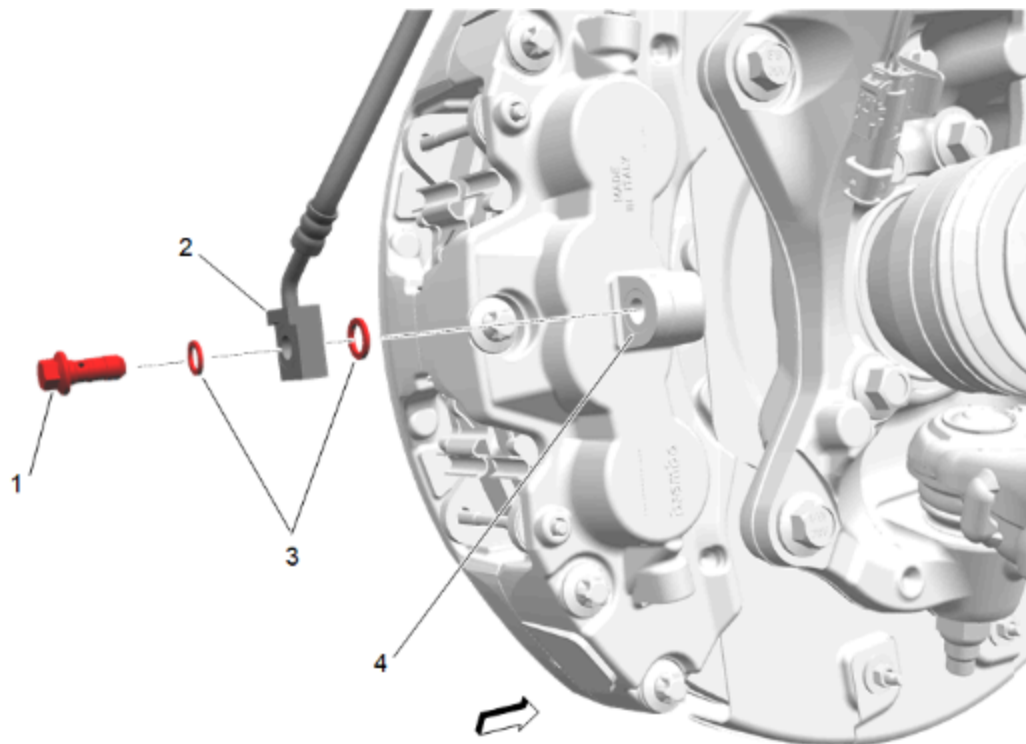

19. Install the new brake hose fitting bolt (1) and gaskets (3) to the brake hose fitting (2) position to caliper (1) and tighten the brake hose fitting bolt to 44 N.m (32 lb ft).

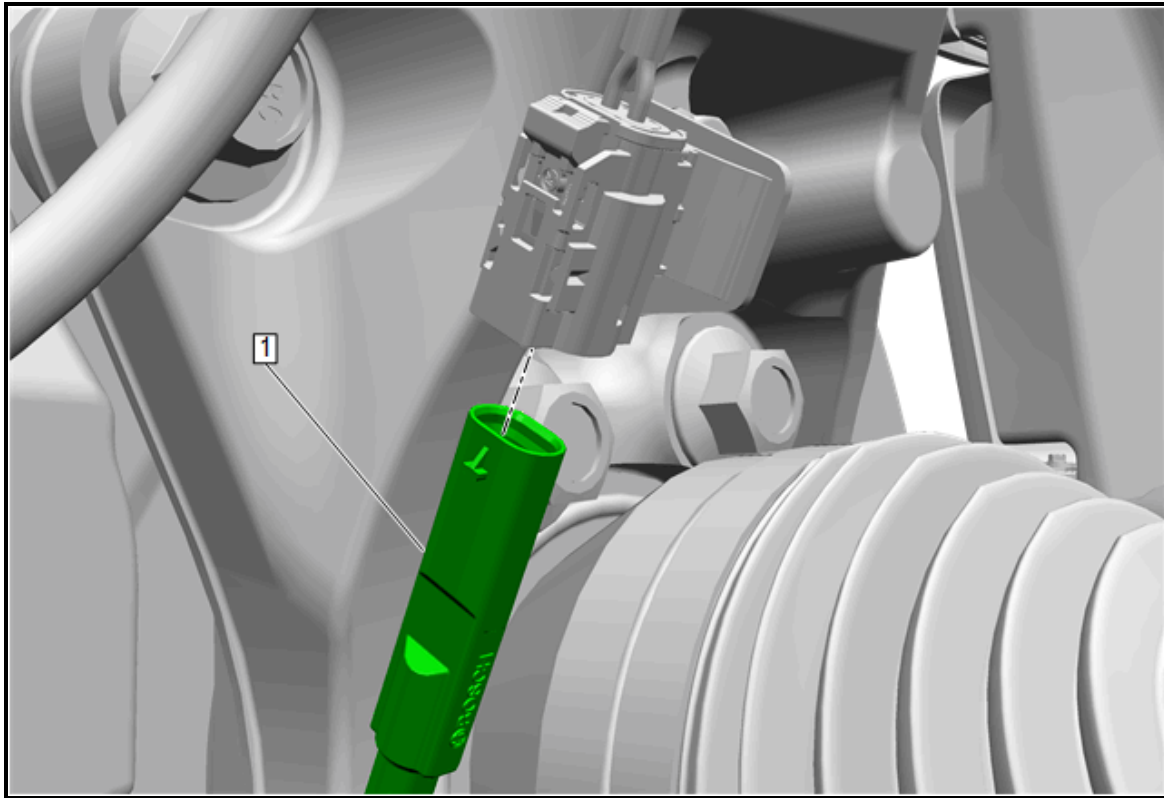

20. Reconnect the front disc brake pad wear sensor (1) (Left Hand Brake Only).

Note: If the Performance Rear Brakes were installed first, proceed to bleed the hydraulic system and burnish the brakes. If not, stop here and proceed to install the Performance Rear Brakes (See Performance Rear Brake Installation Instruction).

21. Bleed the hydraulic brake system. Refer to [Hydraulic Brake System Bleeding](#) in Vehicle Service Manual.

Note: Bleeding one caliper at a time. Right hand side first. Starting with the outboard bleeder screw, bleed until no air is seen, then repeat for the inboard bleeder screw. Repeat for Left hand side caliper.

Note: The torque value for the bleeder screws for the Front Calipers is 17-20 Nm (12.5-14.75 lb ft). It is possible to damage the aluminum caliper if over-torqued.

22. Verify the master cylinder reservoir fluid level.
23. With the engine OFF, gradually apply the brake pedal to approximately 2/3 of its travel distance.
24. Slowly release the brake pedal.
25. Wait 15 seconds, then repeat steps 13 and 14 until a firm brake pedal apply is obtained. This will properly seat the brake caliper pistons and brake pads.
26. Fill the brake master cylinder reservoir to the proper level. Refer to [Brake Master Cylinder Reservoir Filling](#) in Vehicle Service Manual.
27. Install the front tire and wheel assembly. Refer to [Tire and Wheel Removal and Installation](#) in Vehicle Service Manual.
28. Lower the vehicle.
29. Connect the negative battery cable. Refer to [Battery Negative Cable Disconnection and Connection](#) in Vehicle Service Manual.

30. Perform the new brake system control module calibration. This must be performed by a GM Authorized Dealer. Refer to [Control Module References](#) in Vehicle Service Manual.

Brake Pad Monitoring Life Reset

Note: The Brake Pad Life Monitoring Reset Learn is required after installing the Performance Brake Kit.

1. The Brake Pad Life Monitoring Reset Learn procedure can be completed with a scan tool using the following steps:
 - 1.1. Install the scan tool to the data link connector.
 - 1.2. Ignition ON, engine OFF.
 - 1.3. Select the Front Axle Brake Pad Life Monitoring Reset or Rear Axle Brake Pad Life Monitoring Reset in the Brake System Control Module Configuration/Reset Functions list.
 - 1.4. Follow the scan tool directions to complete the reset procedure.
 - 1.5. Clear any DTCs that may be set.
2. Burnish the brake pads and rotors.

Warning: Road test a vehicle under safe conditions and while obeying all traffic laws. Do not attempt any maneuvers that could jeopardize vehicle control. Failure to adhere to these precautions could lead to serious personal injury and vehicle damage.

Note: Burnishing the brake pads and brake rotors is necessary in order to ensure that the braking surfaces are properly prepared after service has been performed on the disc brake system. This procedure should be performed whenever the disc brake rotors have been refinished or replaced, and/or whenever the disc brake pads have been replaced.

3. Select a smooth road with little or no traffic.
4. Accelerate the vehicle to 48 km/h (30 mph).

Note: Use care to avoid overheating the brakes while performing this step.
5. Using moderate to firm pressure, apply the brakes to bring the vehicle to a stop. Do not allow the brakes to lock.
6. Repeat the previous two steps until approximately 20 stops have been completed. Allow sufficient cooling periods between stops in order to properly burnish the brake pads and rotors.
7. Neatly fold the first page of the instruction sheet and include with the owner's manual.

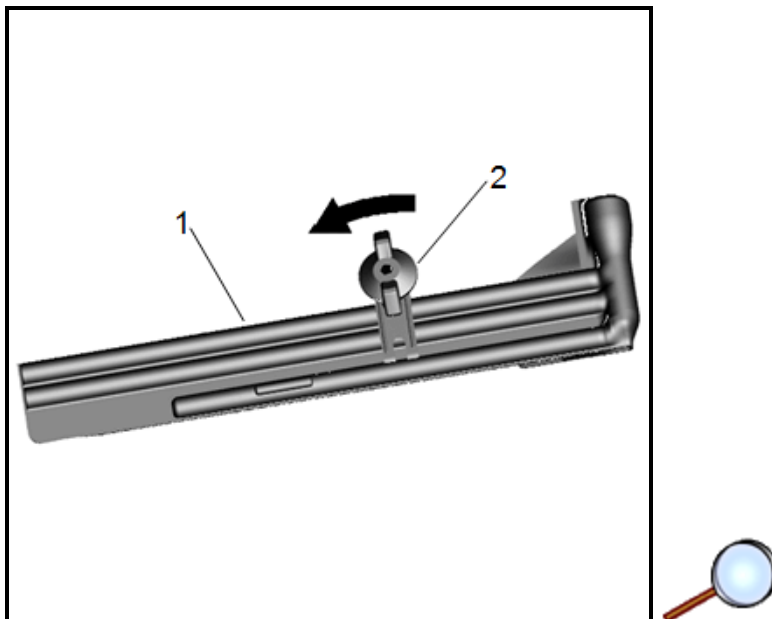

8. **Install Spare Tire Hang Tag:** Install the spare tire caution hang tag to the tool bag (1) by wrapping the elastic cord around the tool bag wing nut (2).
9. Road test the vehicle.