

## Document ID: 6310948

# Pickup Box Divider Divider Package Installation

## Installation Instructions Part Number

85110780

### Kit Contents

Qty	Description
1	Cargo Organizer Base
1	LH Back Panel
1	RH Back Panel
1	Slider Latch
1	LH Side Panel
1	RH Side Panel
2	Side Panel Locking Latch
1	Moveable Divider Panel
4	Floor Spacer
4	Floor Bolts
4	Floor Nuts
4	Hinge Rods
1	Installation Instructions

### Tools Required

Power Drill

5mm, 10mm Drill Bit

Torx Head Drill Bit

10mm Socket/Wrench

GM P/N: 12371287 Corrosion Protectant

### [EV Silverado/Sierra Procedure](#)

**Note:** Steps 8-9 will require the aid of an assistant.

1. This accessory requires removal of the spare tire if equipped for installation access. To remove the spare tire, refer to Si document 5992506 (Tire Changing) in Vehicle Owners Manual.
2. Open the endgate.

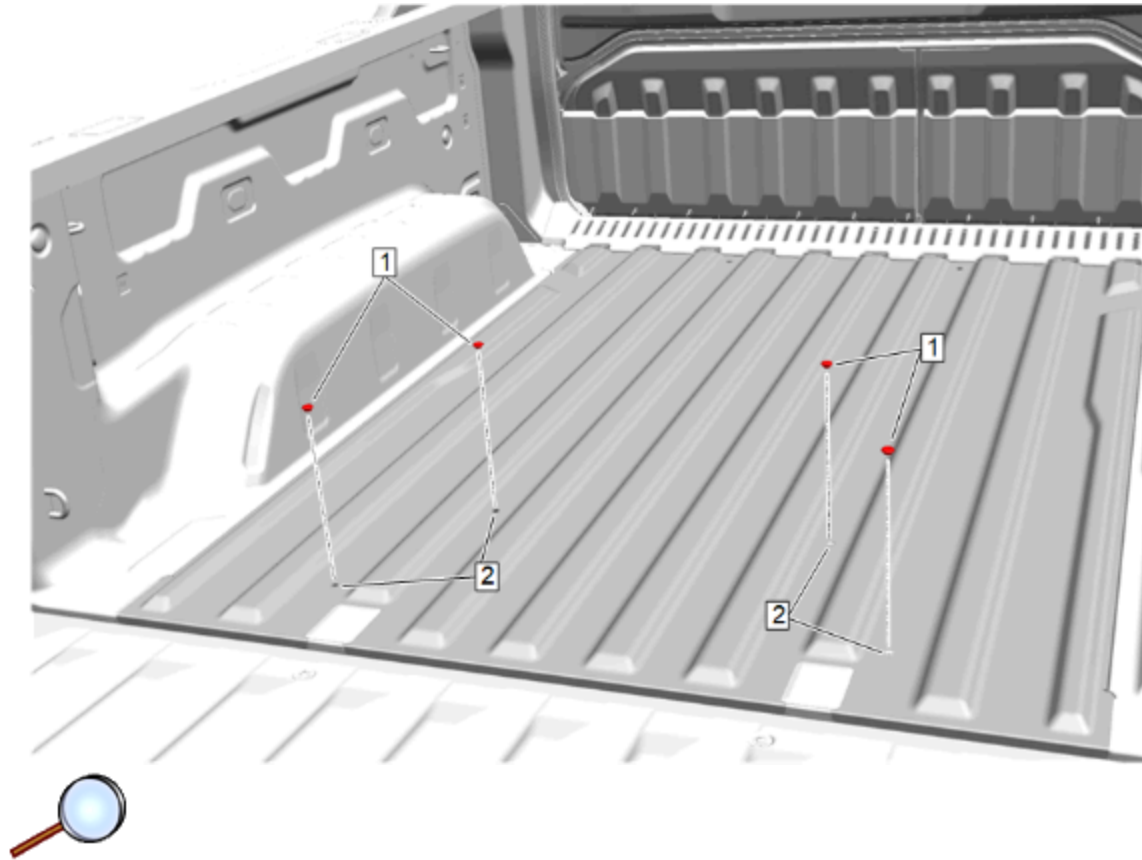

© 2025 General Motors. All rights reserved.

3. Clear rear of truck bed from any dirt or obstructions, clearing the area where the organizer will be installed.
4. Locate and remove the 4 bed plugs (1) to access the attachment holes (2).
5. Remove the underbody rear air rear deflector, if equipped. Refer to [Underbody Rear Air Rear Deflector Replacement](#) in Vehicle Service Manual.

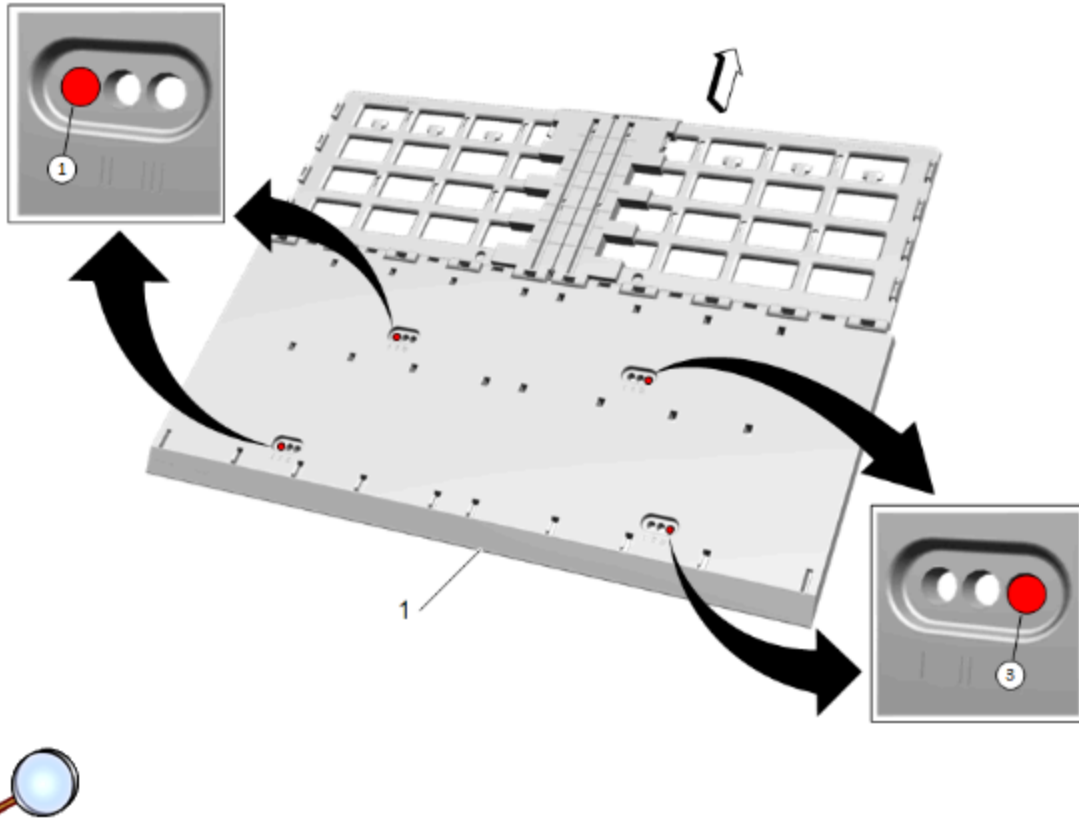

6. Locate the four attachment holes on the cargo organizer base (1). Find the holes in position one for the left side and position three for the right side.

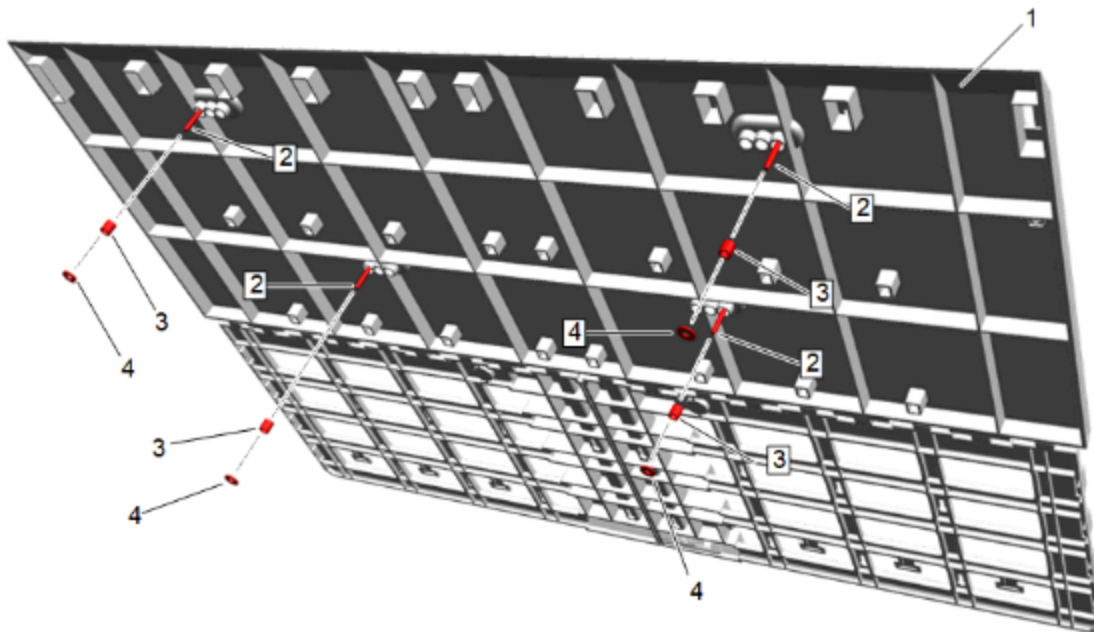

**Caution:** Use the correct fastener in the correct location. Replacement fasteners must be the correct part number for that application. Fasteners requiring replacement or fasteners requiring the use of thread locking compound or sealant are identified in the service procedure. Do not use paints, lubricants, or corrosion inhibitors on fasteners or fastener joint surfaces unless specified. These coatings affect fastener torque and joint clamping force and may damage the fastener. Use the correct tightening sequence and specifications when installing fasteners in order to avoid damage to parts and systems.

7. Place bolt (2) in position one (left side) or position three (right side) holes. Install the four spacers (3) followed by the lock washers (4) to the bolts on the underside of the cargo organizer (1).

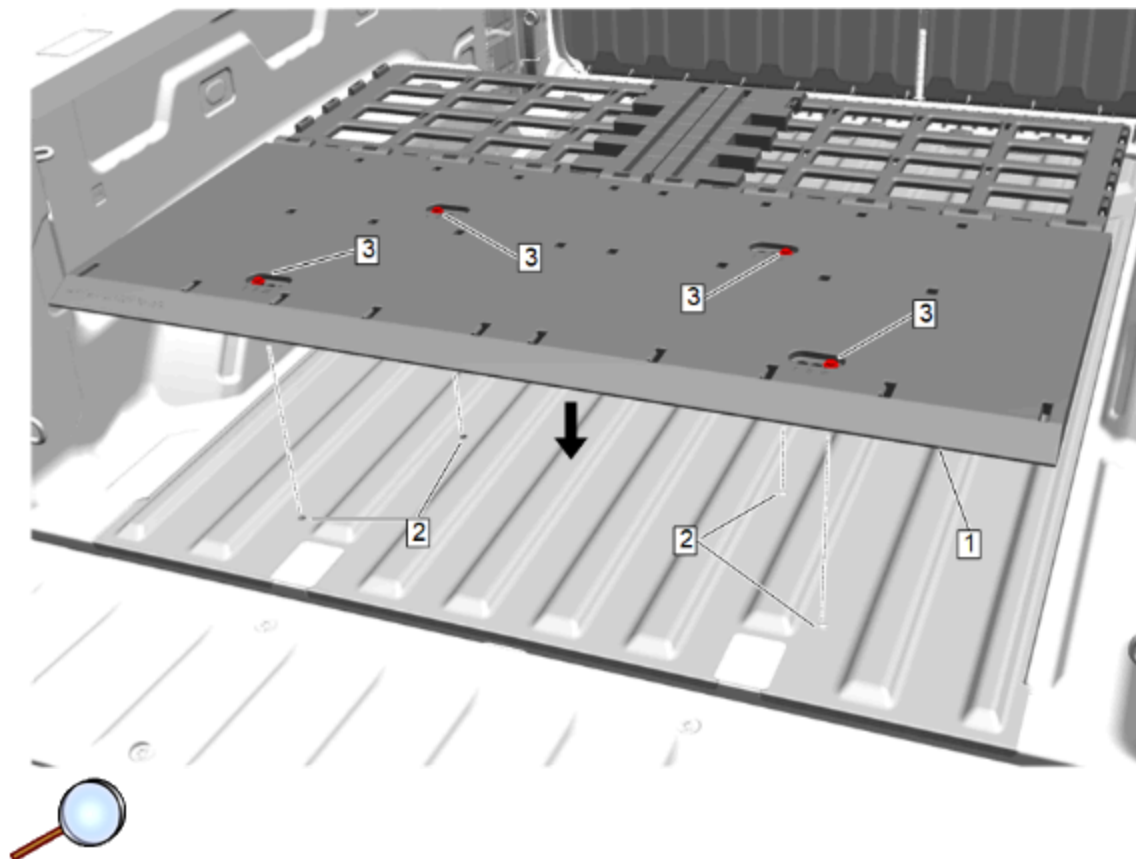

**Note:** Steps 8-9 will require the aid of an assistant.

8. Place the cargo organizer (1) in the pickup box at the edge of the bed floor. Line up the left and right hole positions/bolts (3) on the base of the cargo organizer to the four holes (2) in the bed floor. Make sure spacers are still installed to bolts on the bottom of base.

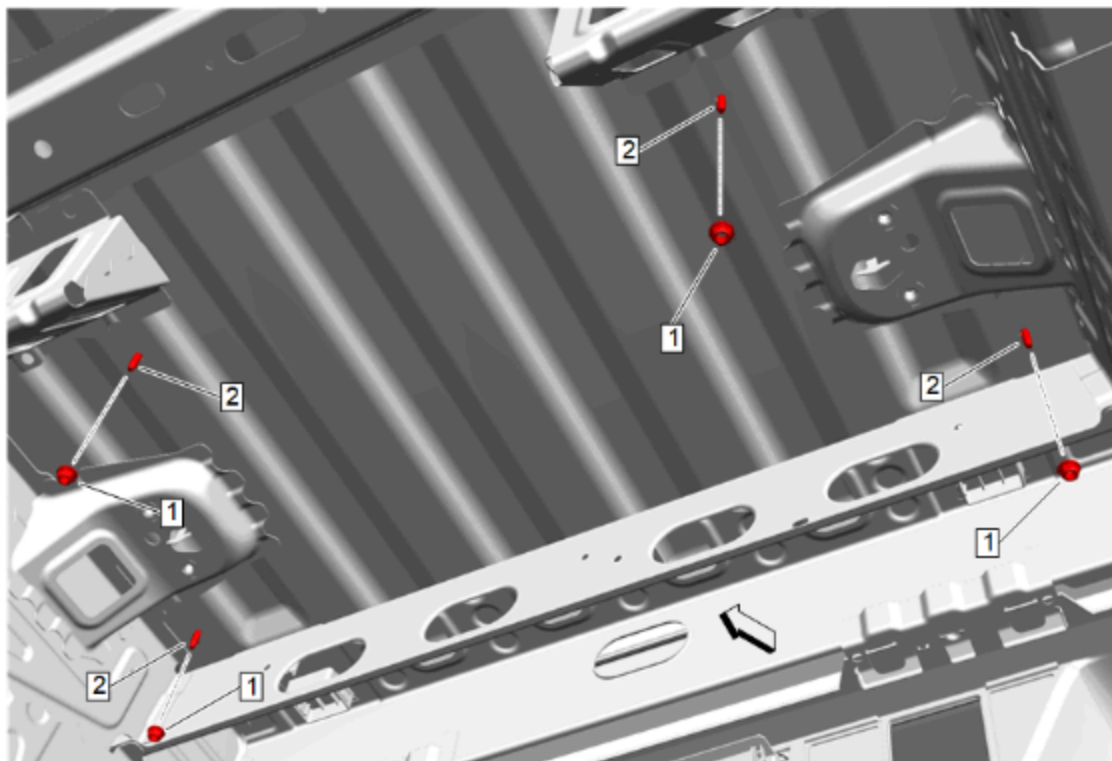

9. One at a time, thread the supplied nuts (1) onto the bolts (2) from underneath the vehicle. With the aid of an assistant, tighten the fasteners to 9 N.m (7 lb ft).

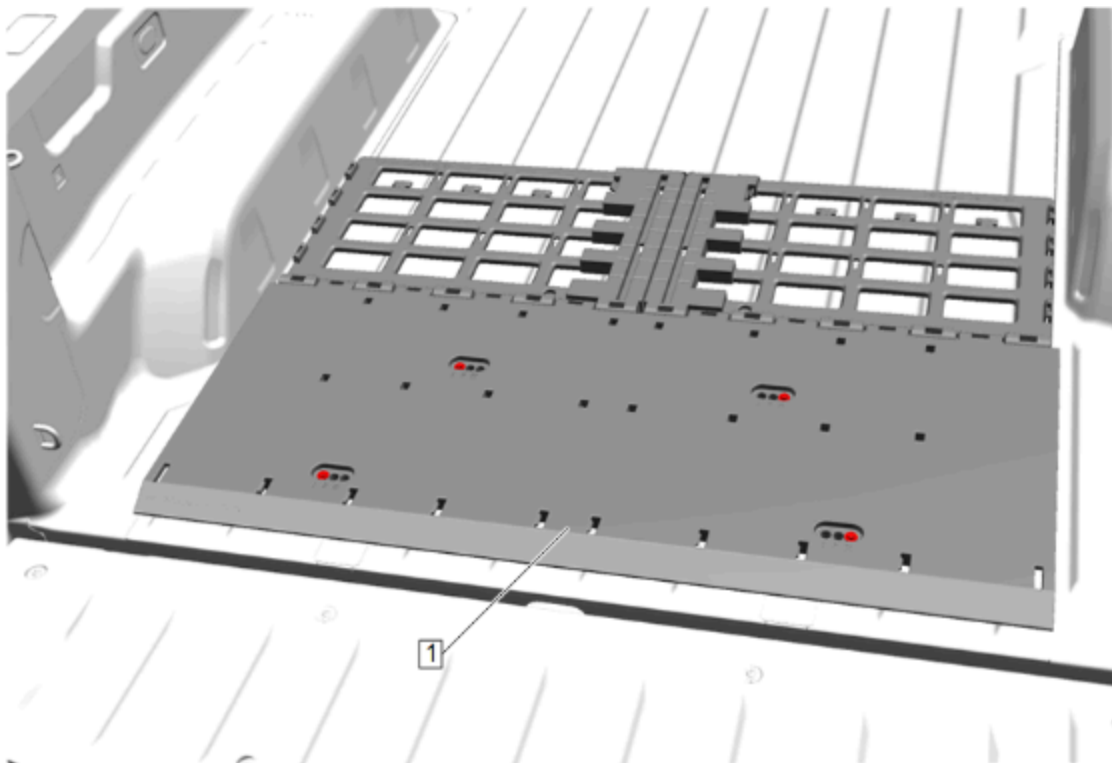

10. Ensure that the cargo organizer base (1) is adequately fastened down.

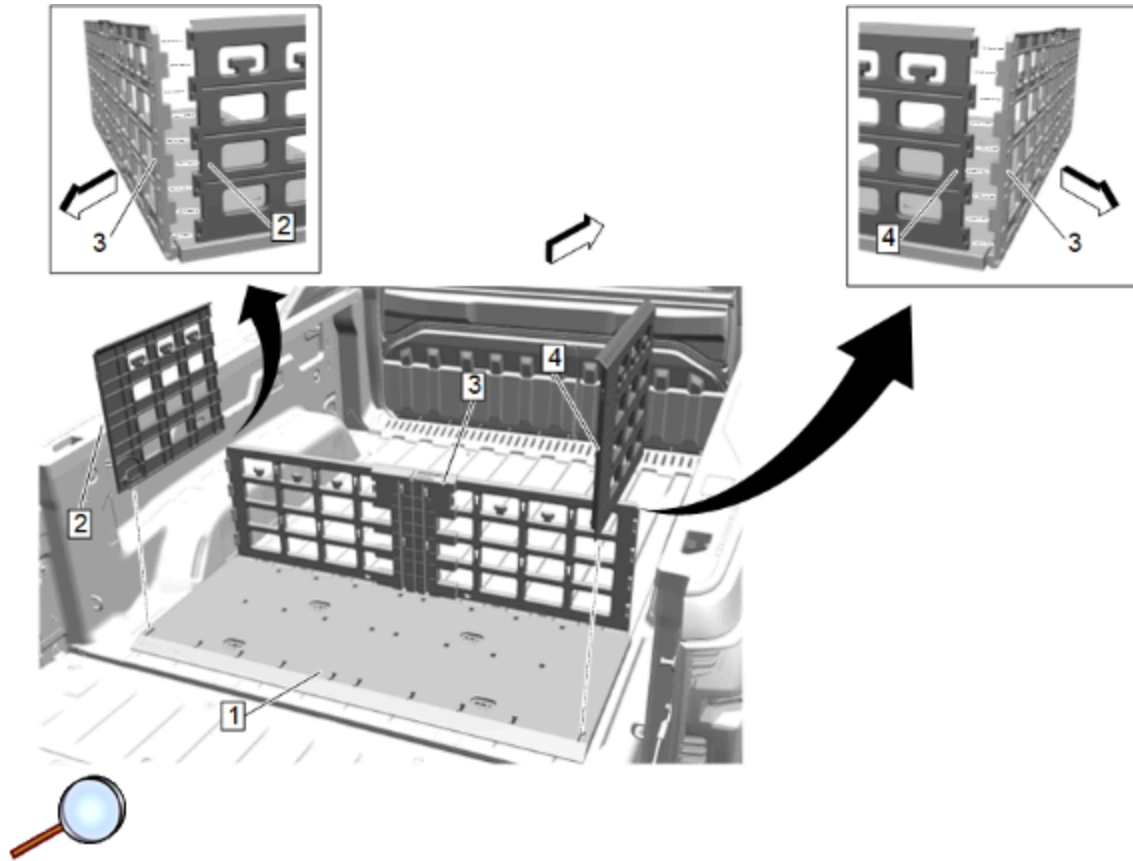

11. Install the left (2) and right (4) side panels into the slot of the organizer base (1) and making sure to line up with the front panels (3).

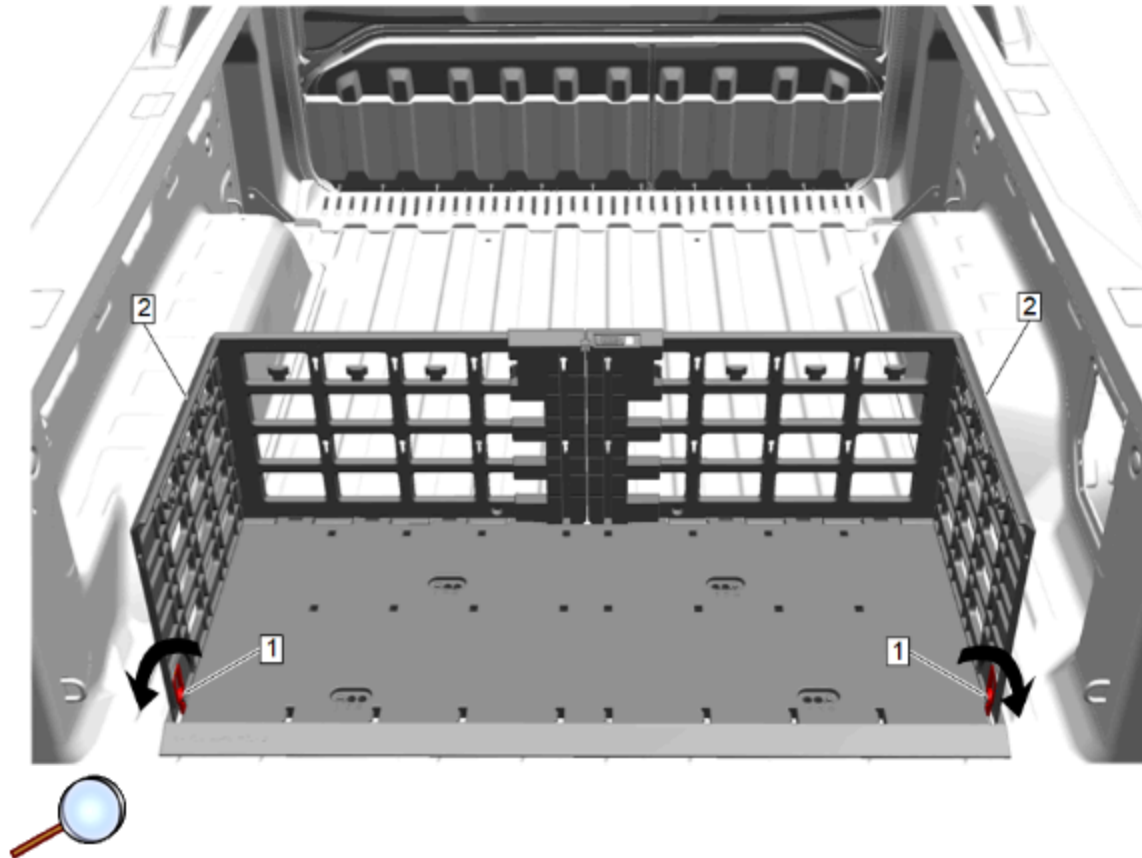

12. Turn the latch (1) to lock the side panels (2) into base.

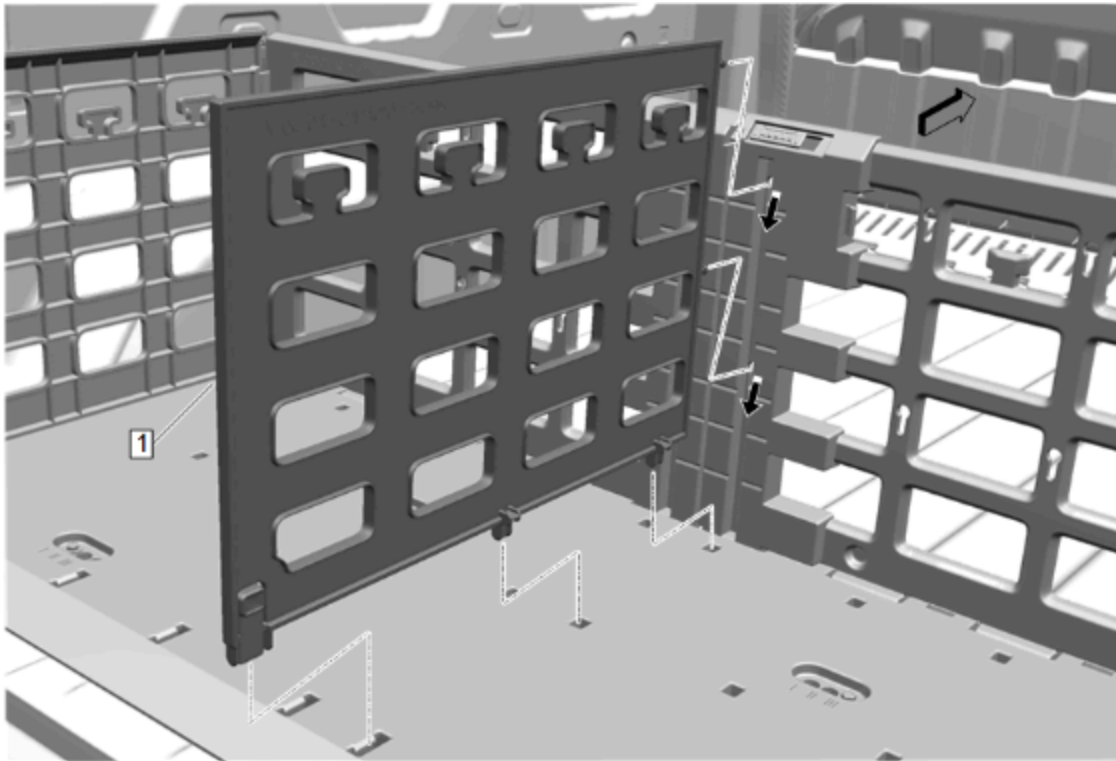

- 13. Insert the press-fit divider (1) into any location.
- 14. Re-install the spare tire if equipped. Refer to Si document 5992506 (Tire Changing) in Vehicle Owners Manual.

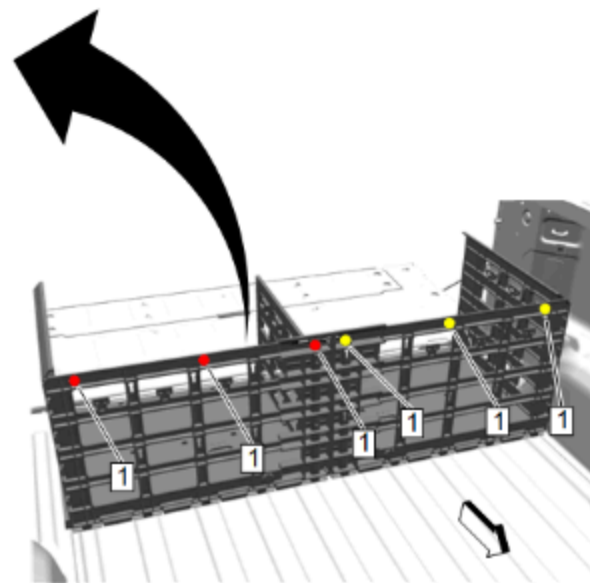
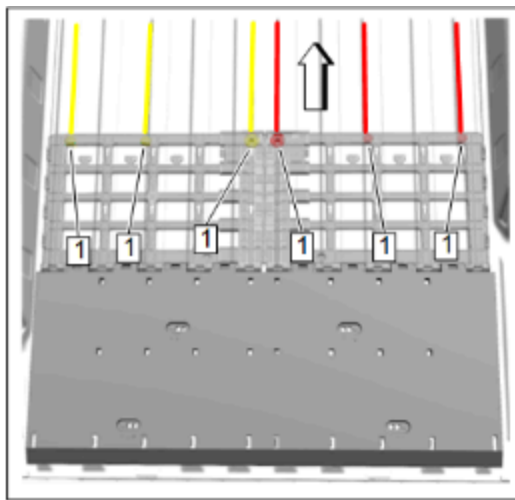



15. To mitigate any possible noise, install noise dampening foam pads. Foam pads (1) get installed to the backside of the back panels relative to your certain vehicle's truck box floor profile.
  - 15.1. Determine proper locations of pads (1) (3 per back panel) by placing the component in the lay flat position. Then note the areas where the floor high points hit each back panel.
  - 15.2. Peel off adhesive cover and place foam pad (1) at the noted locations along the top.
16. Close the endgate.
17. Reinstall the underbody rear air rear deflector, if equipped. Refer to [Underbody Rear Air Rear Deflector Replacement](#) in Vehicle Service Manual.

### **1500 Silverado/Sierra Procedure**

**Note:** Step 9 will require the aid of an assistant.

1. This accessory requires removal of the spare tire if equipped for installation access. To remove the spare tire, refer to Si document 6191824 (Tire Changing) in Vehicle Owners Manual.
2. Open the endgate.
3. Clear rear of truck bed from any dirt or obstructions, clearing the area where the organizer will be installed.

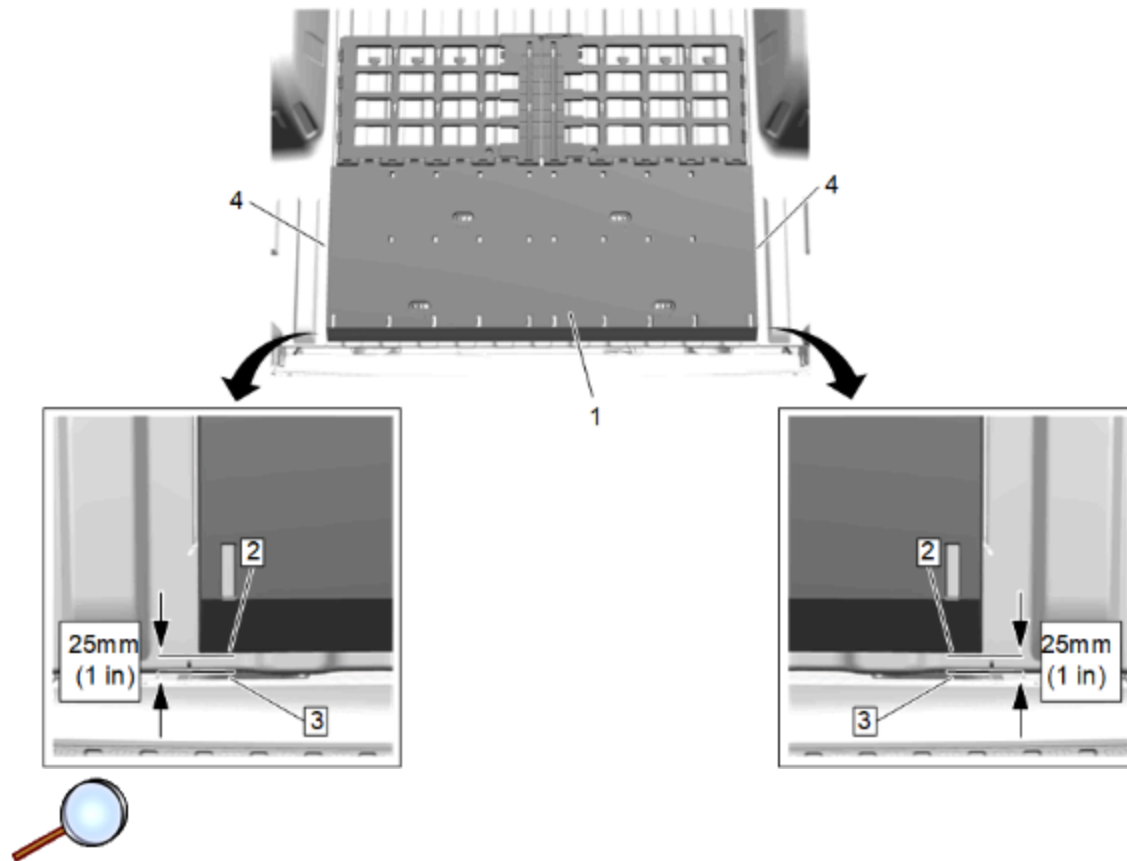

4. Position cargo organizer (1) in pickup box. Organizer will be centered in the vehicle and 1 inch from the end of the pickup box floor. Line sides of the organizer (4) with the side ends of the pickup box floor panel and measure 1 inch from each rear corner of organizer base (2) to the rear end of the pickup box (3).



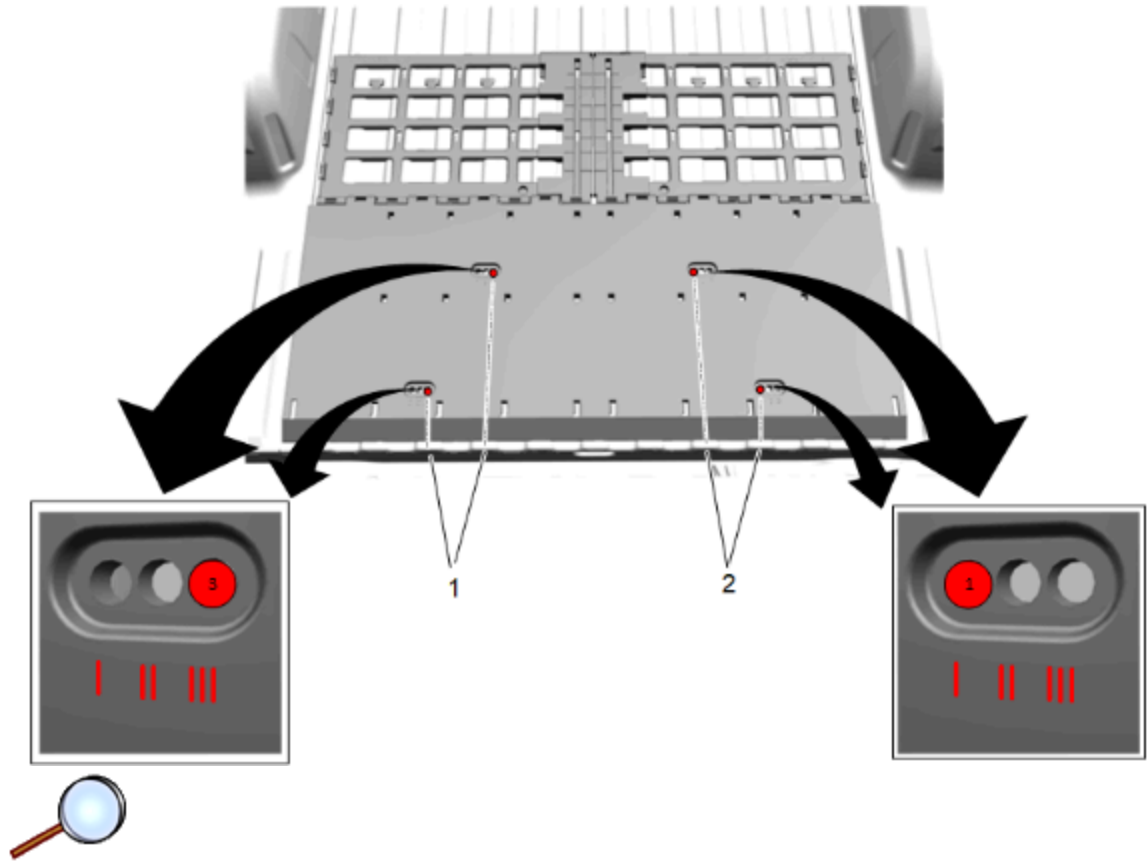

© 2025 General Motors. All rights reserved.

- 4.1. Ensure that the fastener holes (Marked with "III") line up with the crown (peak) of the left pickup box floor ribs (1).
- 4.2. Ensure that the fastener holes (Marked with "I") line up with the crown (peak) of the right pickup box floor ribs (2).
5. Identify and mark drilling locations. Use a center punch to mark drilling locations at the position "III" fastener holes on the left side and position "I" fastener holes on right side of organizer base . If equipped with a spray in bed liner, a white paint pen or alternative may also be used to identify hole centers. Once holes are marked, remove cargo organizer from bed and set aside.
6. Drill holes in the box:

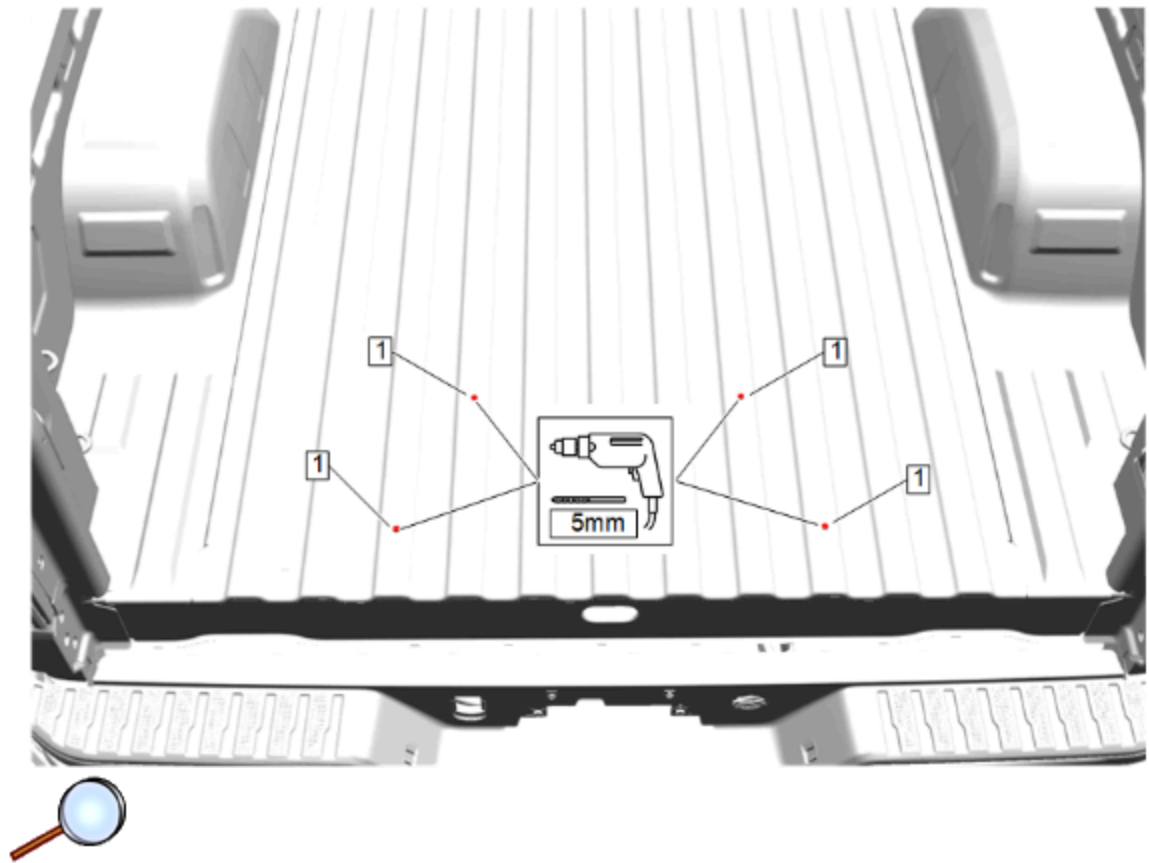

**Caution:** Always check scale, size and position before drilling. Failing to do so may cause damage to the vehicle, misalignment of components or the ability to install the accessory.

- 6.1. Carefully drill 5mm pilot holes (1) at all of the marked locations (4 total). \*IMPORTANT – If available, use a step drill to prevent the drill bit from walking while drilling the holes in the pick-up box floor.

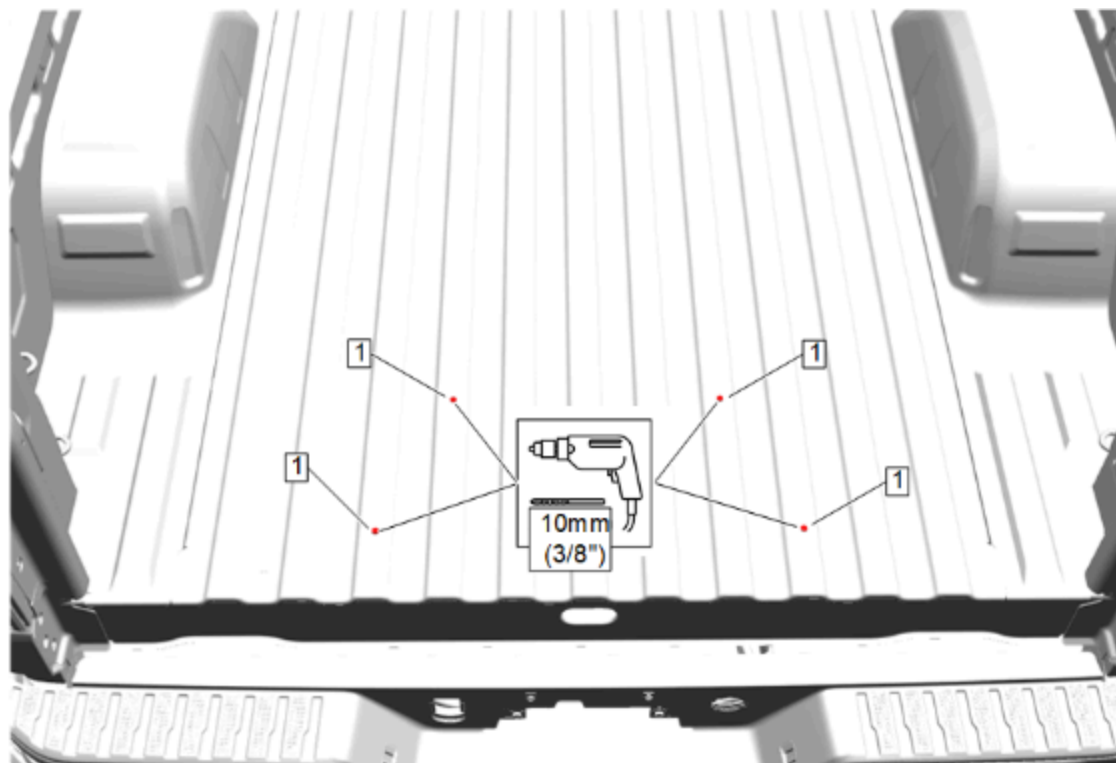

© 2025 General Motors. All rights reserved.

6.2. Set cargo organizer in position to verify hole alignment. Once verified, set organizer aside, and carefully drill all (4 holes) (1) with a 10mm (3/8") drill bit.

6.3. Clear the debris from the pick-up box, and apply corrosion inhibitor (GM P/N: 12371287) to all the holes drilled into the pick-up box.

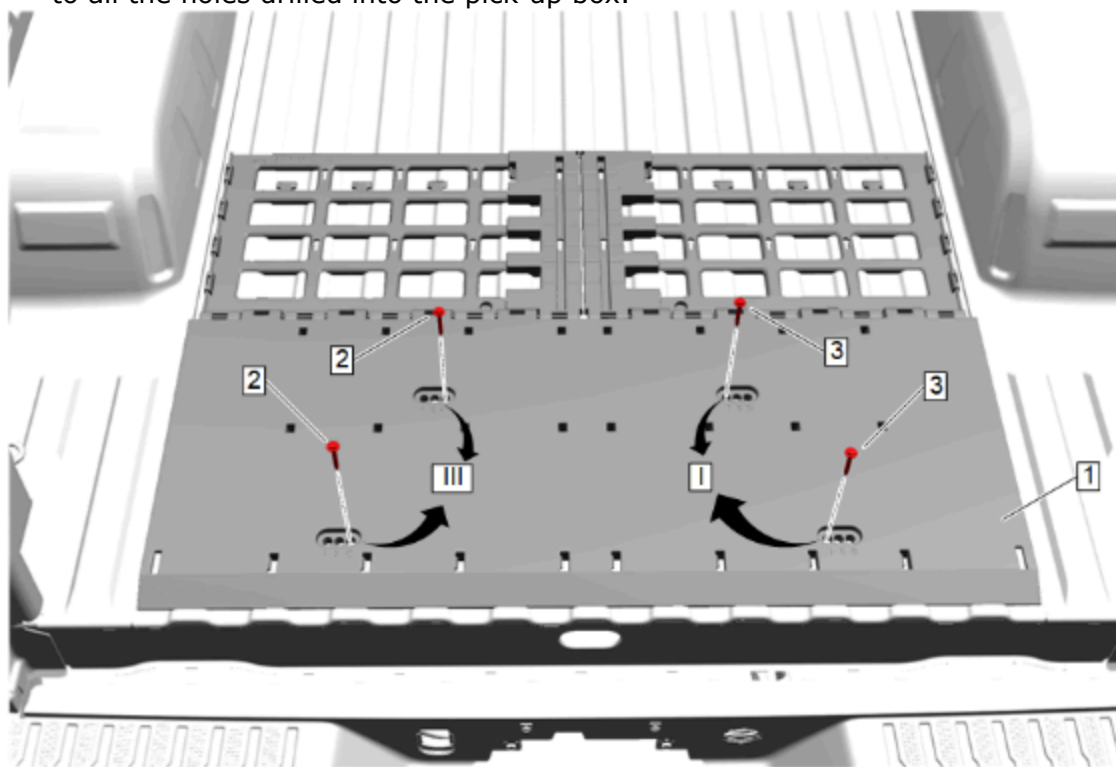

**Caution:** Use the correct fastener in the correct location. Replacement fasteners must be the correct part number for that application. Fasteners requiring replacement or fasteners requiring the use of thread locking compound or sealant are identified in the service procedure. Do not use paints, lubricants, or corrosion inhibitors on fasteners or fastener joint surfaces unless specified. These coatings affect fastener torque and joint clamping force and may damage the fastener. Use the correct tightening sequence and specifications when installing fasteners in order to avoid damage to parts and systems.

7. Insert the supplied bolts (2) through the organizer (1) in position "III" and the bed floor.
8. Insert the supplied bolts (3) through the organizer (1) in position "I" and the bed floor.

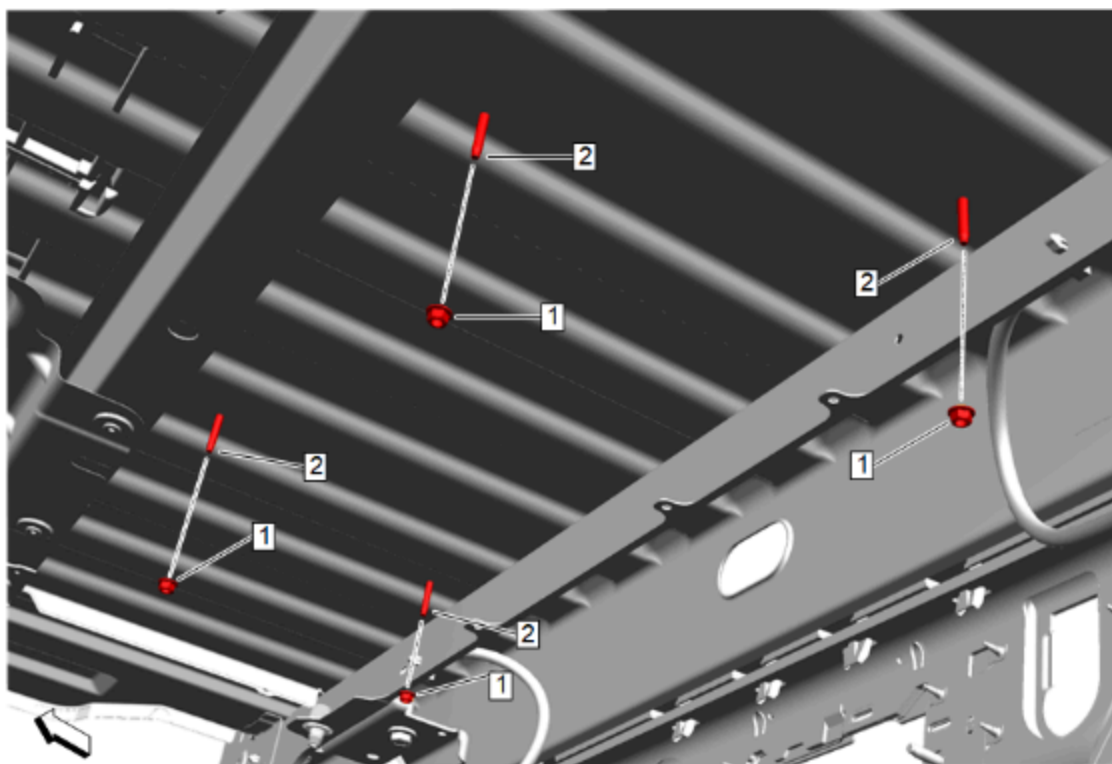

**Note:** Step 9 will require the aid of an assistant.

9. One at a time, thread the supplied nuts (1) onto the bolts (2) from underneath the vehicle. With the aid of an assistant, tighten the fasteners to 9 N.m (7 lb ft).

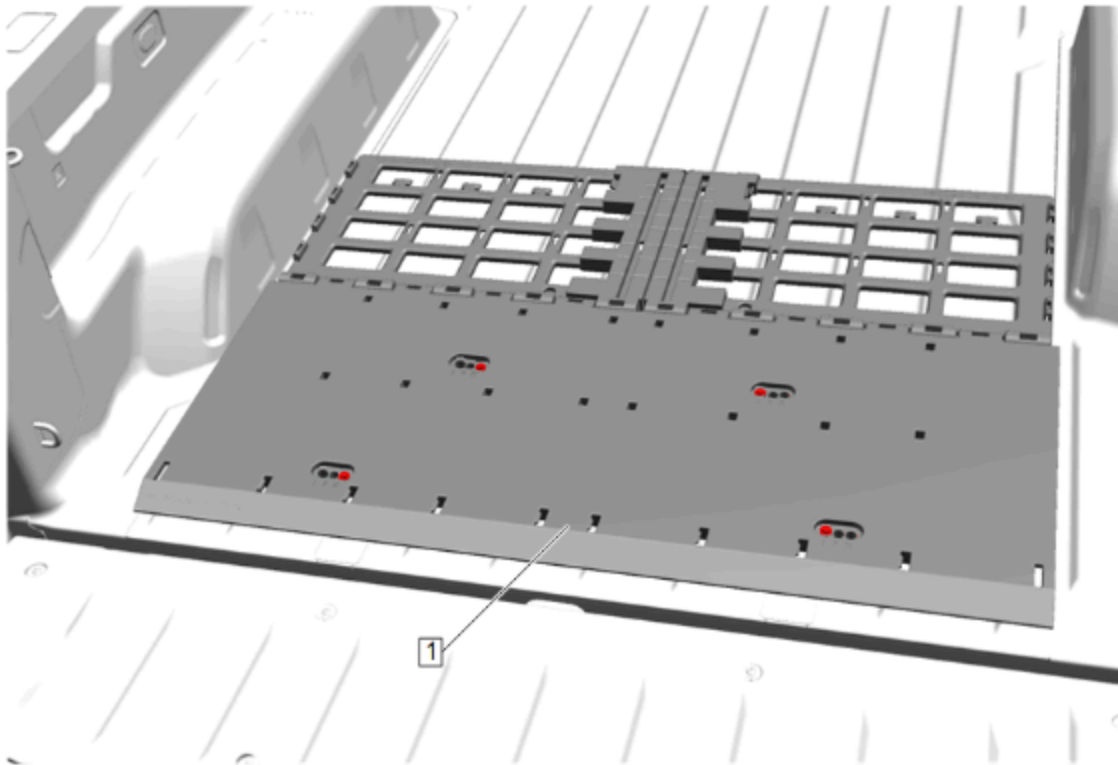

10. Ensure that the cargo organizer base (1) is adequately fastened down.

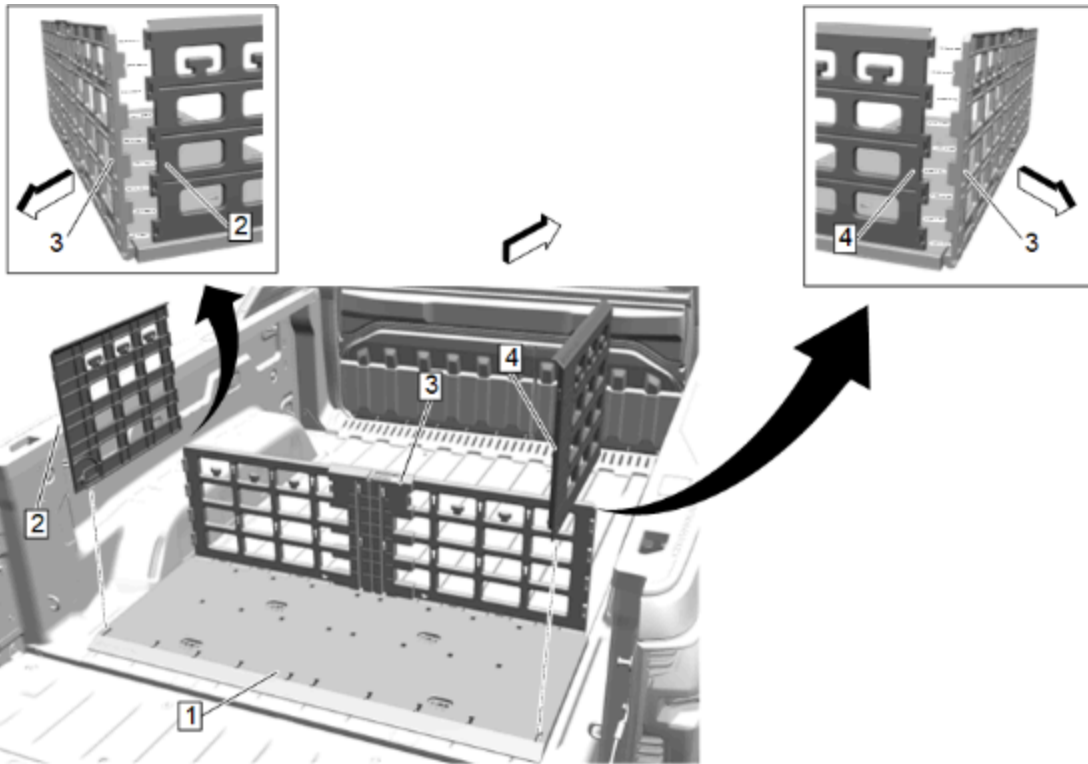

11. Install the left (2) and right (4) side panels into the slot of the organizer base (1) and making sure to line up with the front panels (3).

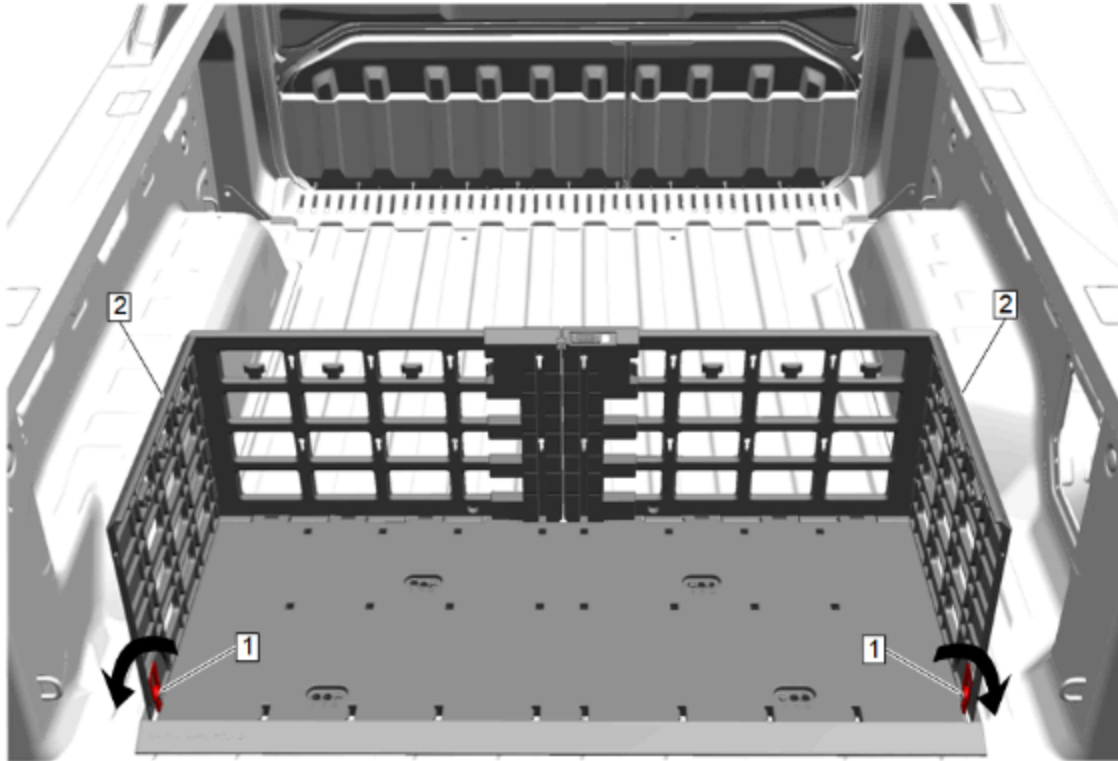

12. Turn the latch (1) to lock the side panels (2) into base.

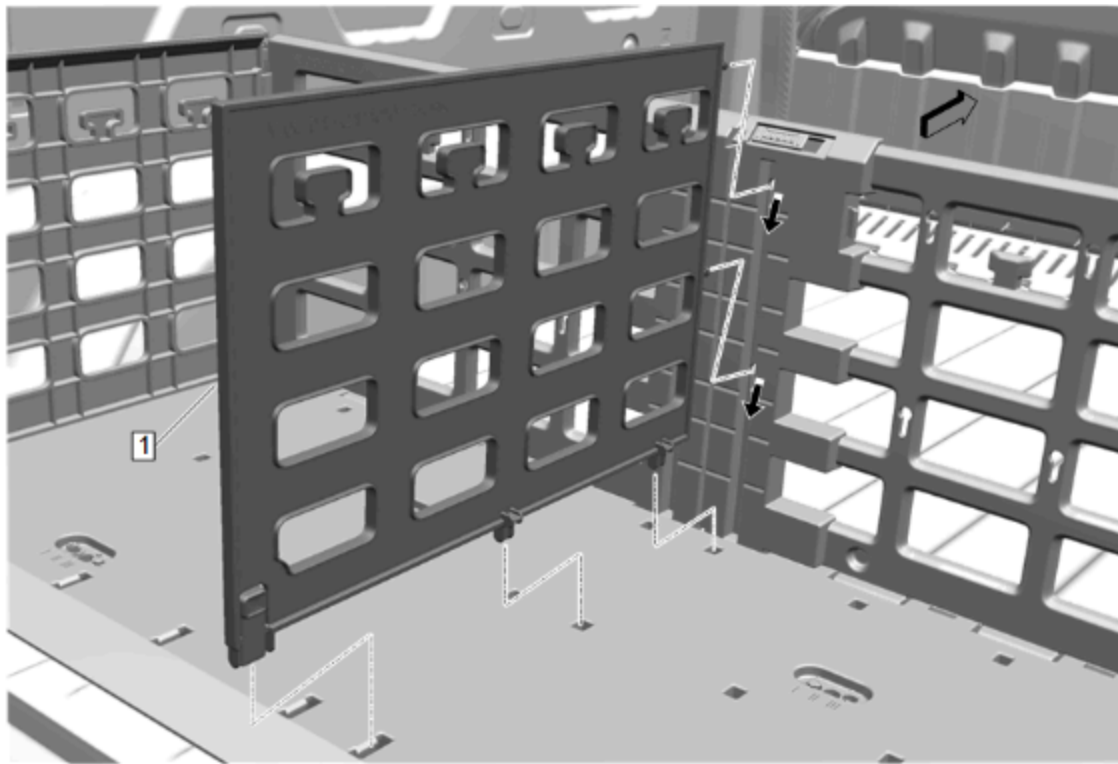

13. Insert the press-fit divider (1) into any location.

14. Re-install the spare tire if equipped. Refer to Si document 6191824 (Tire Changing) in Vehicle Owners Manual.

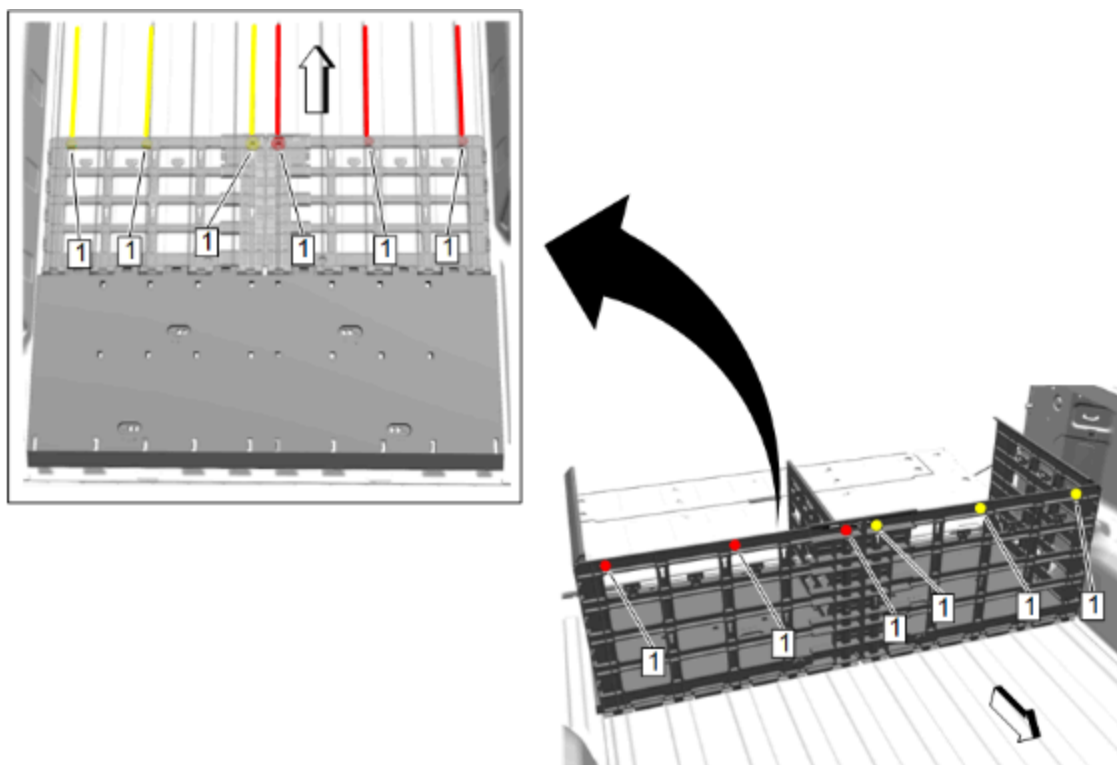

15. To mitigate any possible noise, install noise dampening foam pads. Foam pads (1) get installed to the backside of the back panels relative to your certain vehicle's truck box floor profile.
- 15.1. Determine proper locations of pads (1) (3 per back panel) by placing the component in the lay flat position. Then note the areas where the floor high points hit each back panel.
- 15.2. Peel off adhesive cover and place foam pad (1) at the noted locations along the top.
16. Close the endgate.