

Document ID: 4800842

Assist Step Kit Installation

Installation Instructions Part Number

84067185

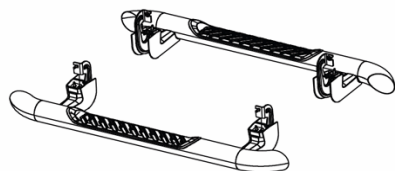

Side Step Regular Cab

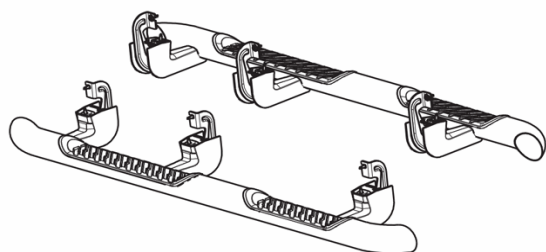

Side Step Extended Cab

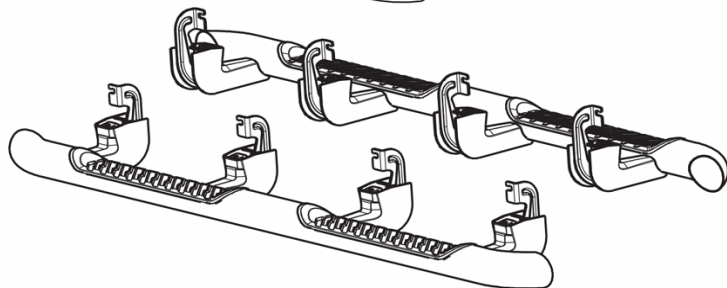

Side Step Crew Cab



Kit Contents

Item	Description	Qty: Regular Cab	Qty: Extended Cab	Qty: Crew Cab
1	Tube Assembly Driver Side	1	1	1
2	Tube Assembly Passenger Side	1	1	1
3	M8 Bolt	8	12	16

© 2018 General Motors. All rights reserved.

Item	Description	Qty: Regular Cab	Qty: Extended Cab	Qty: Crew Cab
4	Instruction Sheet	1	1	1

Torque Table

8mm Hardware torque to 25N•m (18 lb ft)

Tools Required

- Torque Wrench
- 13mm Socket
- 3/8" drive Ratchet
- 3" 3/8" drive extension

Note: Read entire instruction sheet (5) thoroughly before starting.

Note: Determine left hand and right hand tubular assist steps.

Caution: Use the correct fastener in the correct location. Replacement fasteners must be the correct part number for that application. Fasteners requiring replacement or fasteners requiring the use of thread locking compound or sealant are identified in the service procedure. Do not use paints, lubricants, or corrosion inhibitors on fasteners or fastener joint surfaces unless specified. These coatings affect fastener torque and joint clamping force and may damage the fastener. Use the correct tightening sequence and specifications when installing fasteners in order to avoid damage to parts and systems.

Bracket Positions (Left Hand Side Shown, Right Hand Side Opposite)

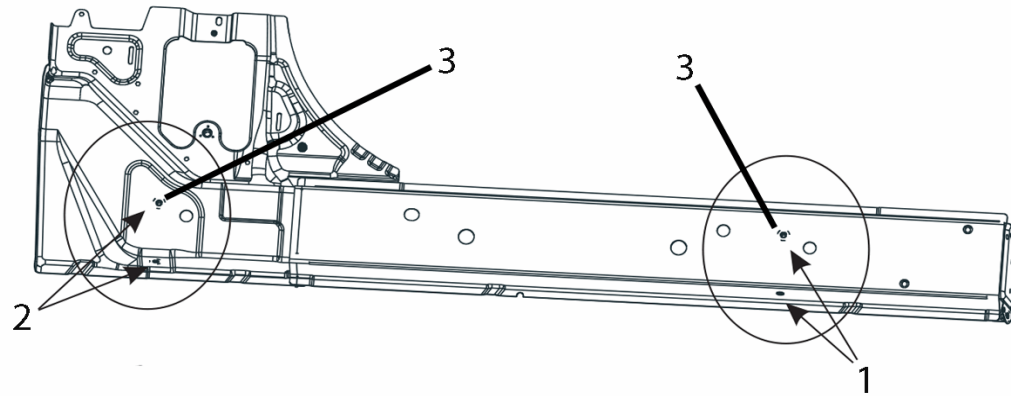

Note: Remove weld nut plug (3) if necessary.

1. Regular Cab:

- 1.1. Location one (1).
- 1.2. Location two (2).

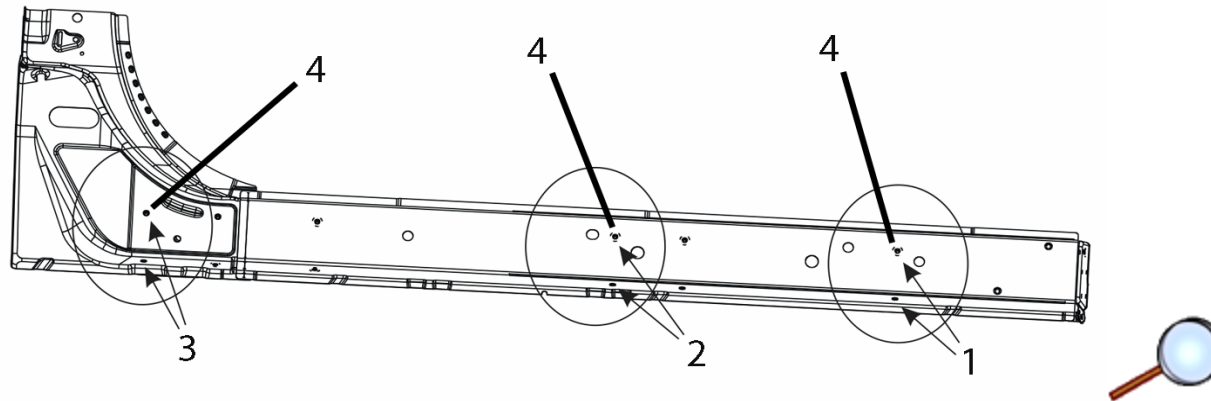

Note: Remove weld nut plug (4) if necessary.

2. Extended Cab:

- 2.1. Location one (1).
- 2.2. Location two (2).
- 2.3. Location three (3).

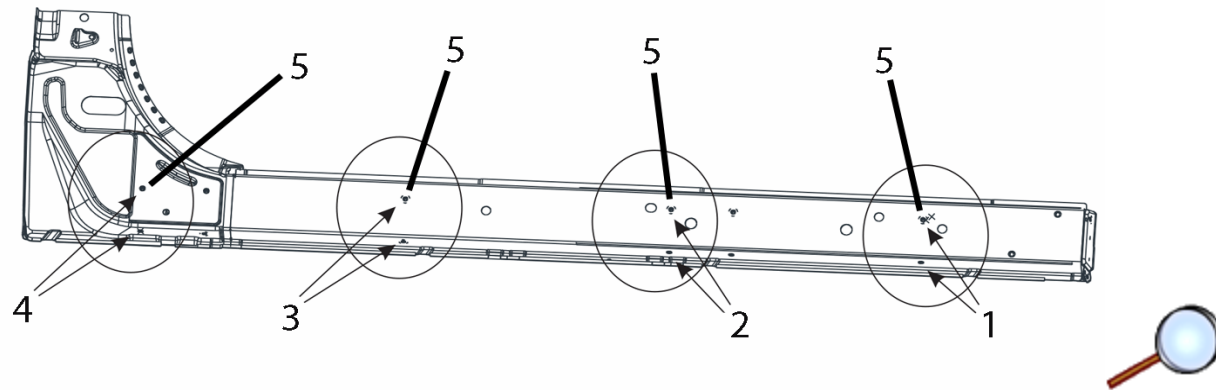

Note: Remove weld nut plug (5) if necessary.

3. Crew Cab:

- 3.1. Location one (1).
- 3.2. Location two (2).
- 3.3. Location three (3).
- 3.4. Location four (4).

Procedure

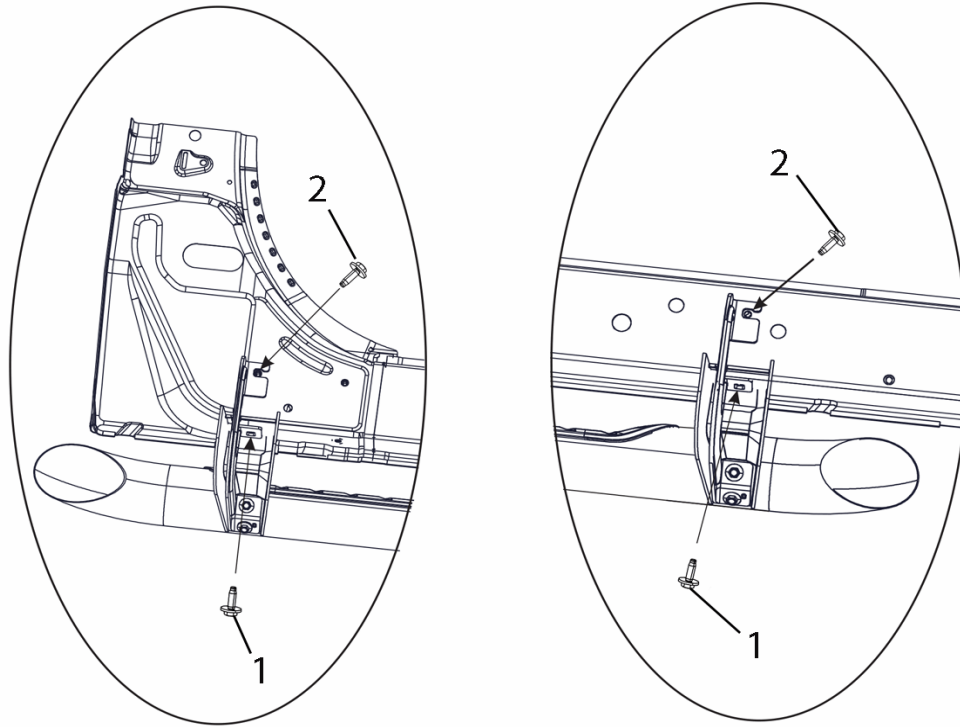

1. Position the left hand side assist step to the inner rocker panel and secure by hanging rear bracket. Then hang the front bracket, by loosely installing M8 bolt (2) Item 3 to side step inner panel weld nut.
2. From underneath, loosely insert M8 bolts (1) Item 3 through bracket, rocker panel and into lower weld nut.
3. Tighten the M8 bolts (1) in lower positions to 25 N-m (18 lb ft) in the following order: front, rear, and middle.
4. Repeat previous step for the upper positions (2). Tighten bolts to 25 N-m (18 lb ft).
5. Repeat all previous steps for RH side tubular assist step assembly.

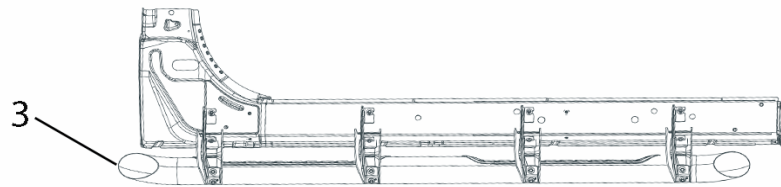
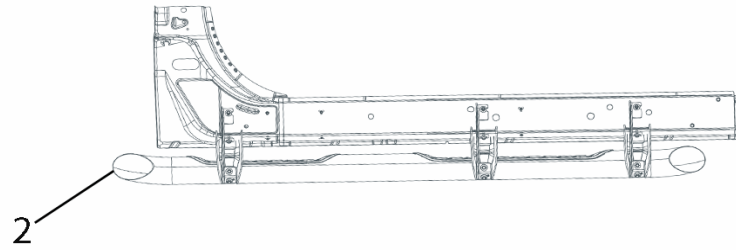
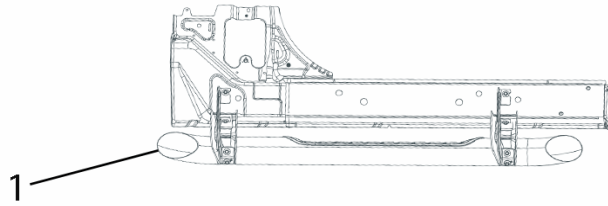

6. Verify correct torque on all hardware:

- 6.1. Regular Cab (1).
- 6.2. Extended Cab (2).
- 6.3. Crew Cab (3).