

# SHERPA™ 2.0

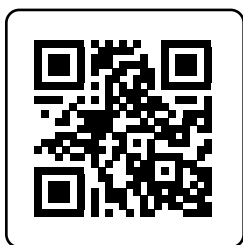

ASSEMBLY VIDEO

Parts:

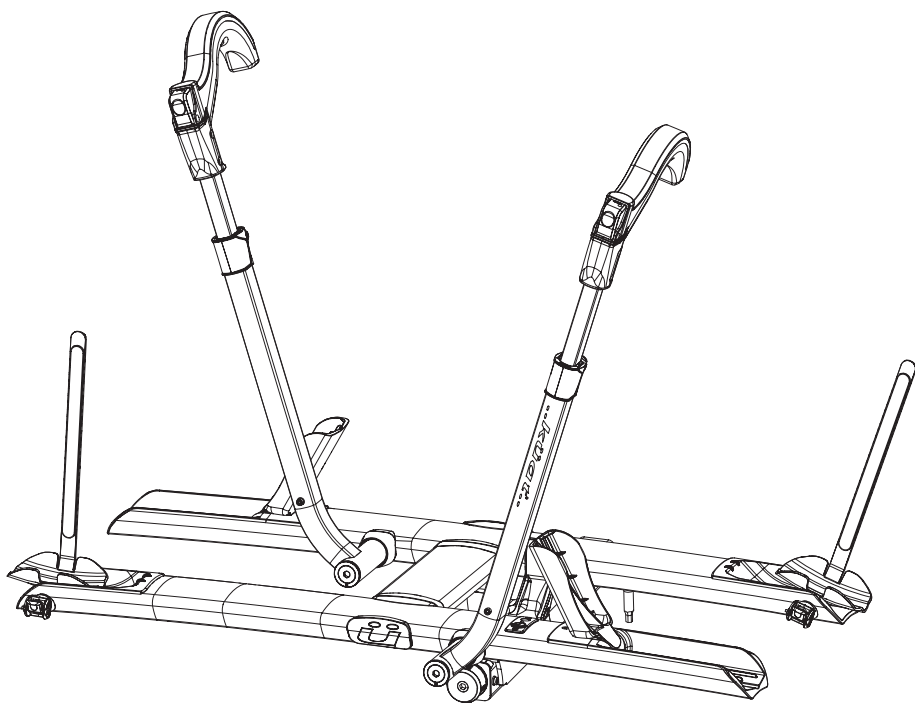
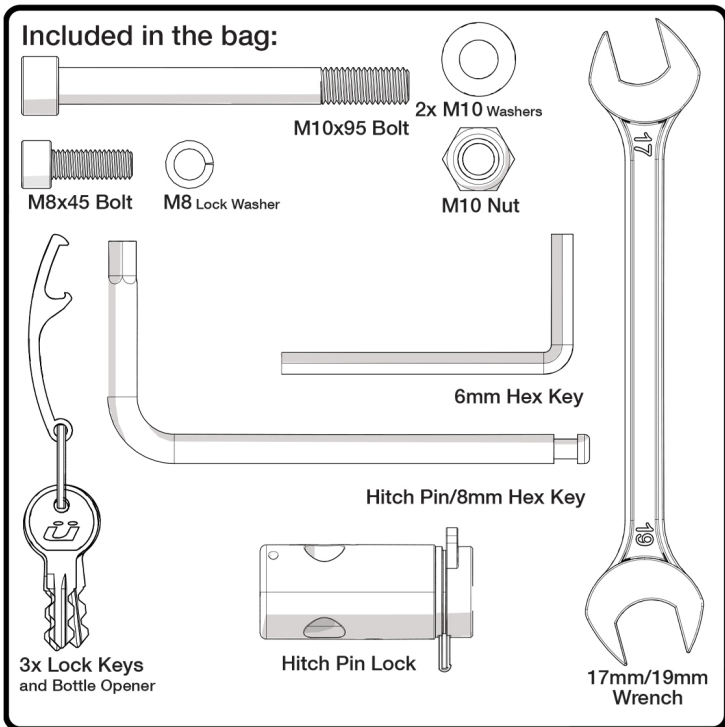
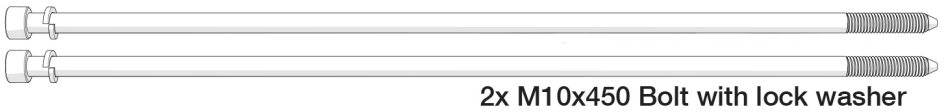
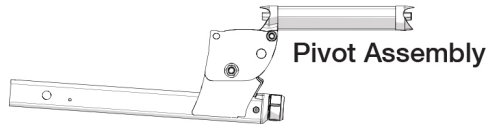
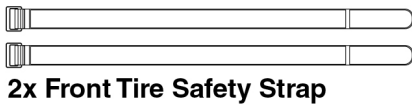
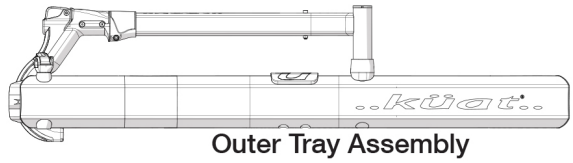
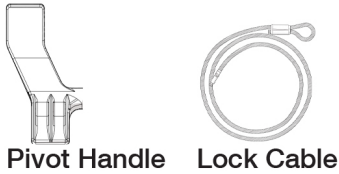
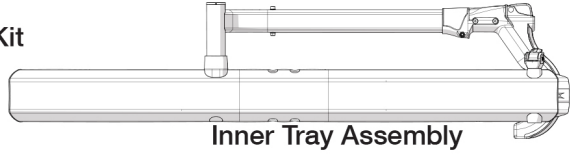
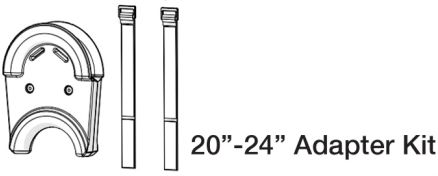

# Unpacking and assembly instructions.

**STEP 1.** Remove parts box and bracing. Open parts box.

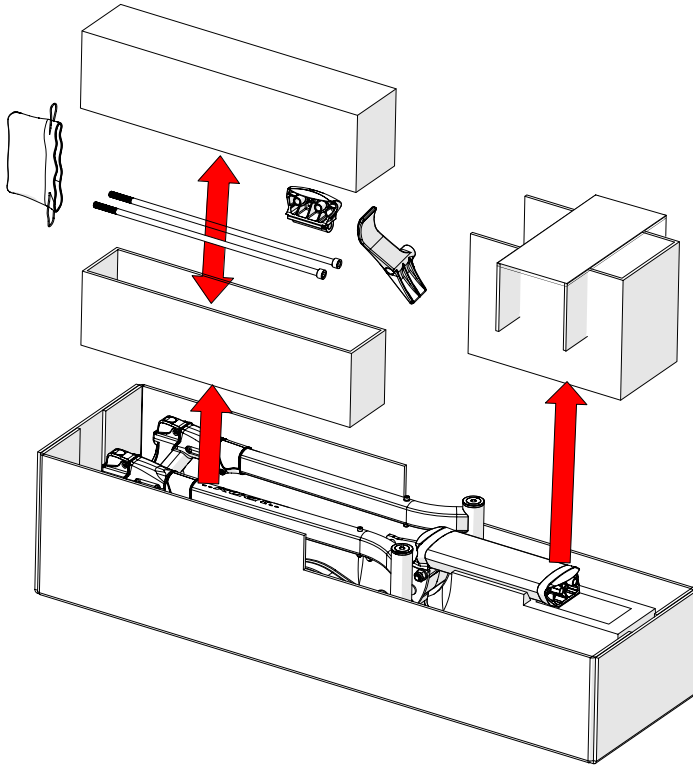

**STEP 2.** Remove trays. **DO NOT** remove hitch assembly.

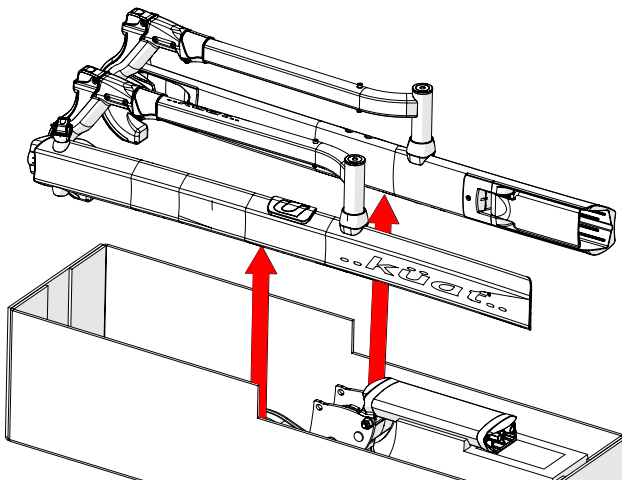

**PRO TIP:** Assembly for the SHERPA™ 2.0 can be made easier by keeping the hitch assembly inside in the box.

### STEP 3. Place trays into build position.

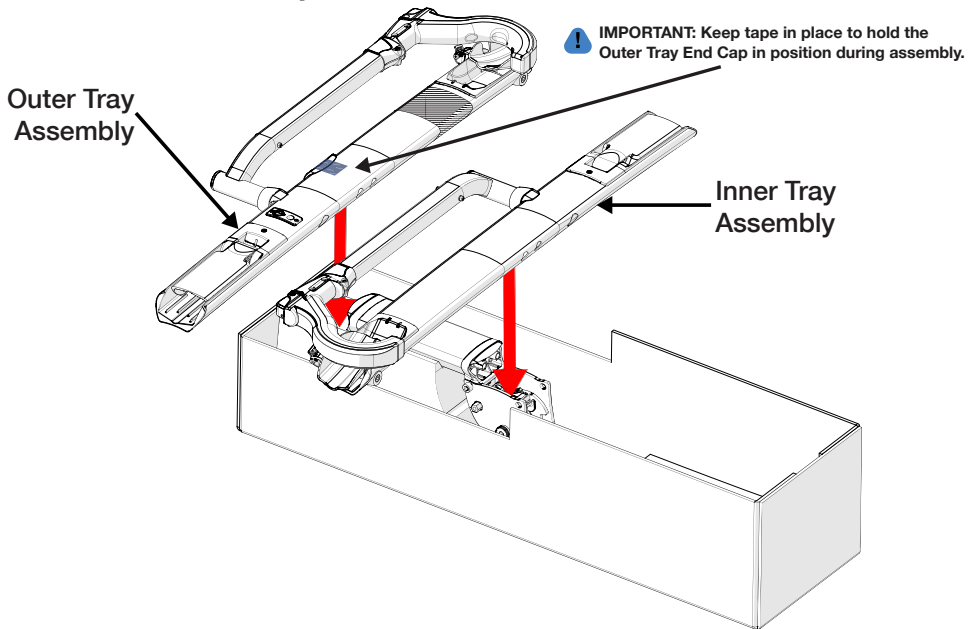

### STEP 4. Assemble trays.

Parts Needed:

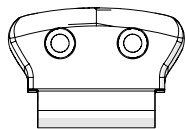

x1 Rear Tray Mount

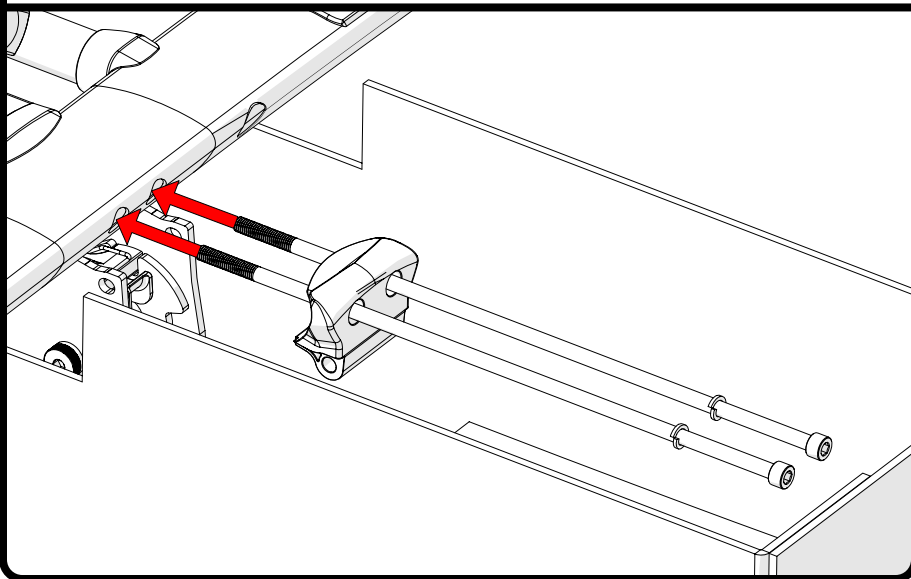
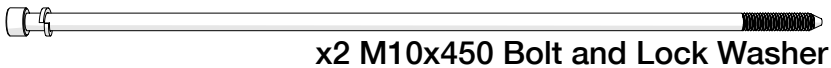

**NOTE:** Using the Hitch Pin/8mm Hex Key, tighten to 15ft-lbs (20 Nm), alternating bolts between each turn. Excessive tightening will damage the rack.

**NOTA:** Usando el pasador de enganche/llave hexagonal de 8 mm, apriete a 20 Nm pernos alternos entre cada vuelta. Un ajuste excesivo dañará la rejilla.

**REMARQUE:** À l'aide de la goupille d'attelage/clé hexagonale de 8 mm, serrez à 20 Nm, alterner les boulons entre chaque tour. Un serrage excessif endommagerait le support.

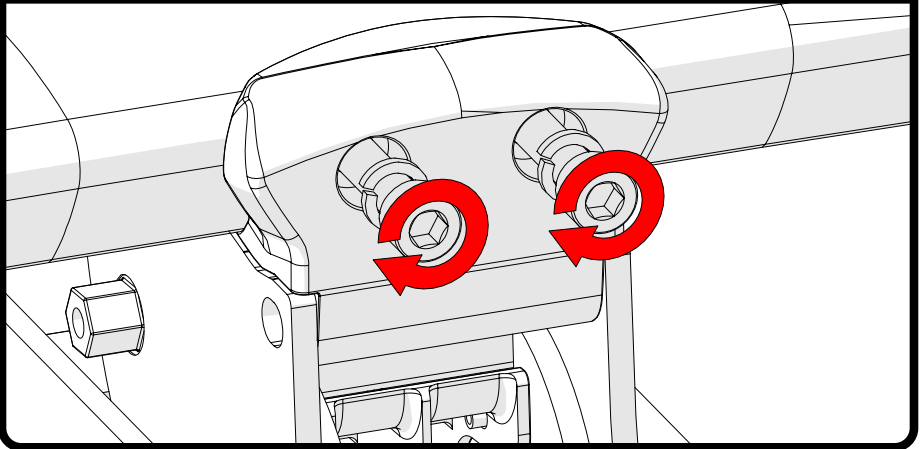

### STEP 5. Install rear tray bolt.

Parts Needed:



x1 M10x95 Bolt

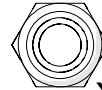

x1 M10 Locknut

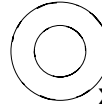

x2 M10 Washer

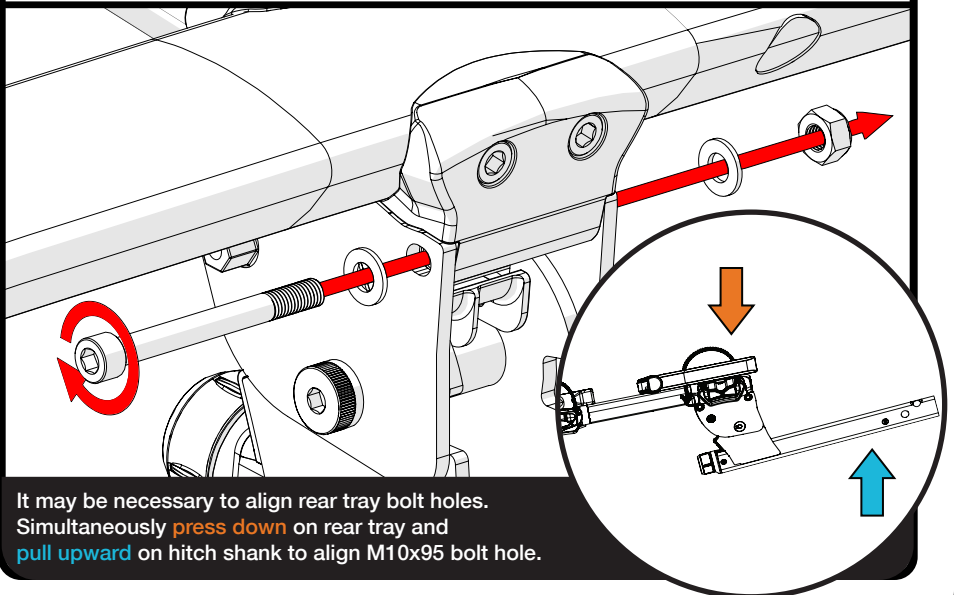

It may be necessary to align rear tray bolt holes. Simultaneously **press down** on rear tray and **pull upward** on hitch shank to align M10x95 bolt hole.

## STEP 6. Install pivot handle.

### Parts Needed:



x1 M8x45 Bolt



x1 M8 Lock Washer

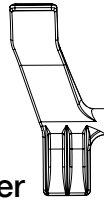

x1 Pivot  
Handle/Pedal

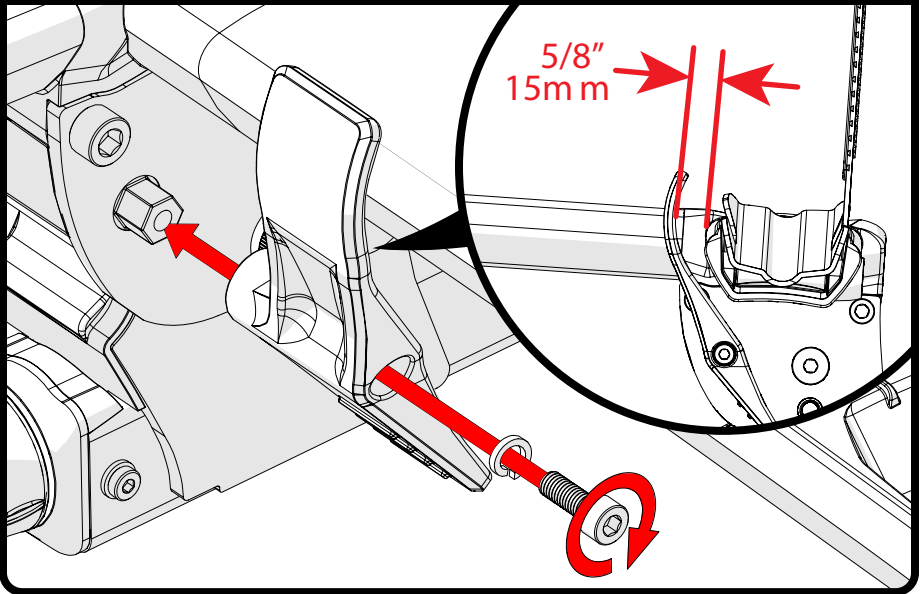

**NOTE:** After first use, check the main tray bolts for loosening and re-tighten if needed. Max 15ft-lbs (20 Nm).

**NOTA:** Después del primer uso, verifique que los pernos de la bandeja principal no estén flojos y vuelva a apretarlos si es necesario. Máximo 20 Nm.

**REMARQUE :** Après la première utilisation, vérifiez que les boulons du plateau principal sont desserrés et resserrez-les si nécessaire. Max 20 Nm.

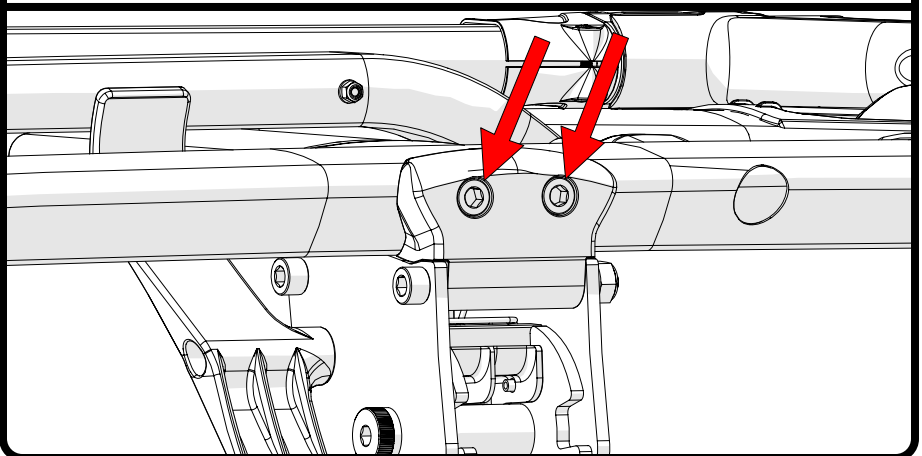

# Installation instructions.

STEP 1. Install into hitch receiver.

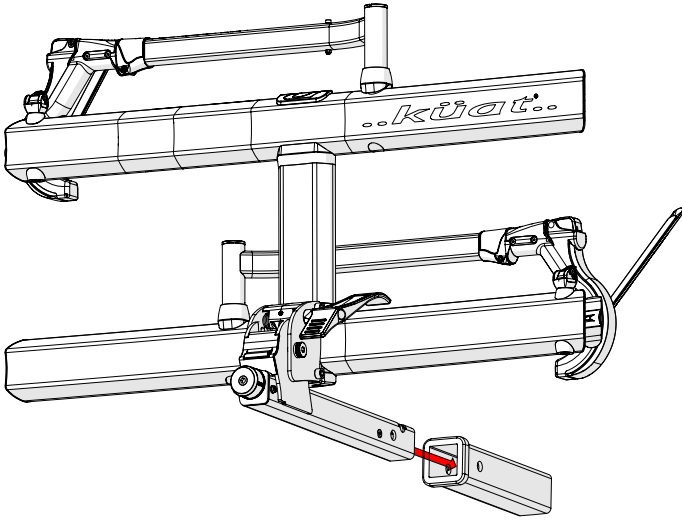

STEP 2. Attach the locking pin. Turn the knob to tighten the hitch cam.

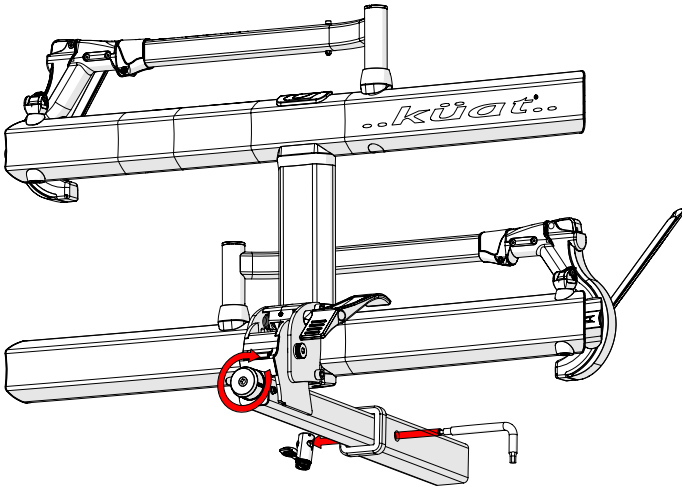

Please note the proximity to vehicle exhaust. Direct exposure to exhaust may cause heat related damage to your bicycle or rack.

# Loading bicycles.

**STEP 1.** Pivot the tray assembly down, using the pivot handle to release the tray.

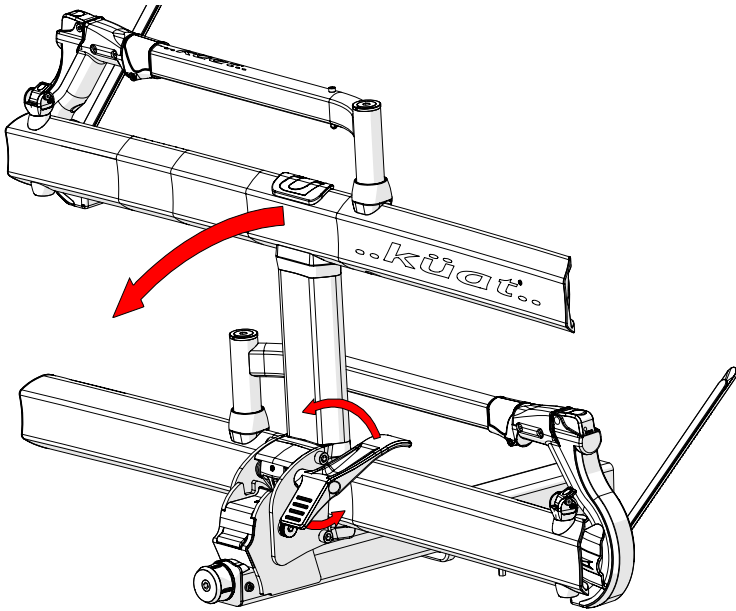

**STEP 2.** Open the front tire cradles.

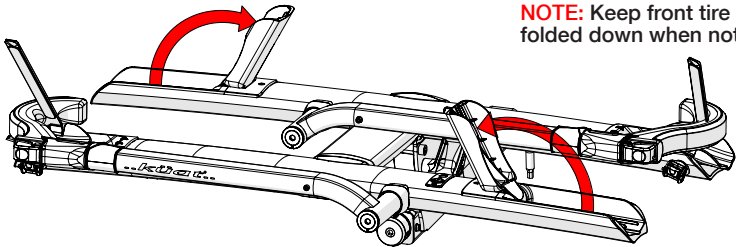

**NOTE:** Keep front tire cradles folded down when not in use.

**STEP 3.** Fold out the front tire hooks.

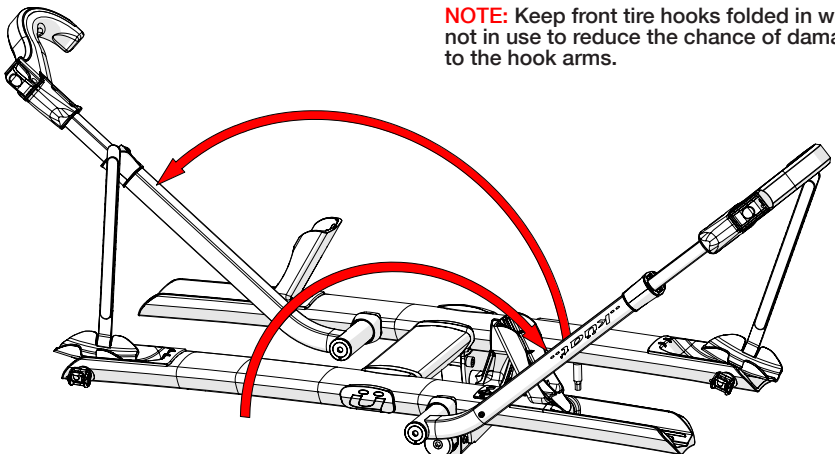

**NOTE:** Keep front tire hooks folded in when not in use to reduce the chance of damage to the hook arms.



**STEP 4.** Position the front tire hook against the tire and as close to the fork as possible.

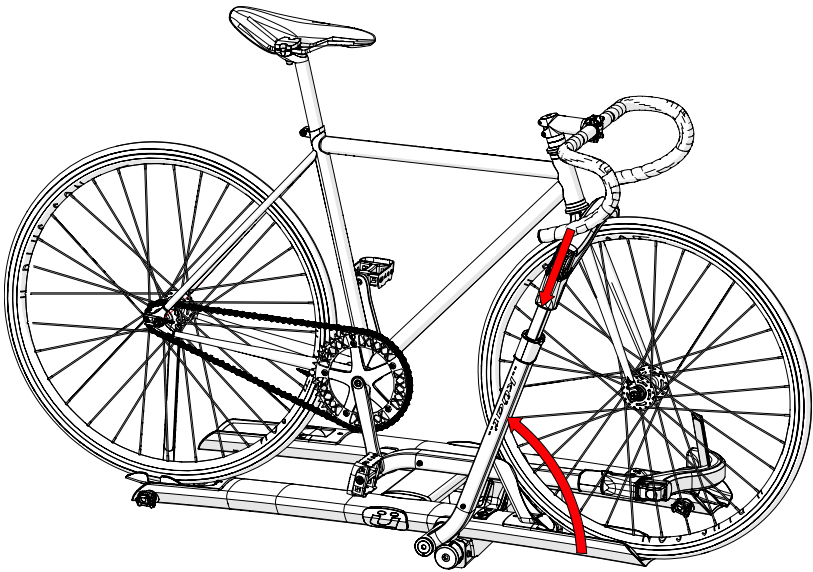

**NOTE:** Proper placement of the tire hook is critical to securing the bicycle to the rack. The tire hook should be as close to the fork as possible.

**NOTA:** La colocación adecuada del gancho para llantas es fundamental para asegurar la bicicleta al portabicicletas. El gancho para neumáticos debe estar lo más cerca posible de la horquilla.

**REMARQUE:** Le placement correct du crochet pour pneu est essentiel pour fixer le vélo au porte-vélos. Le crochet de pneu doit être aussi près que possible de la fourche.

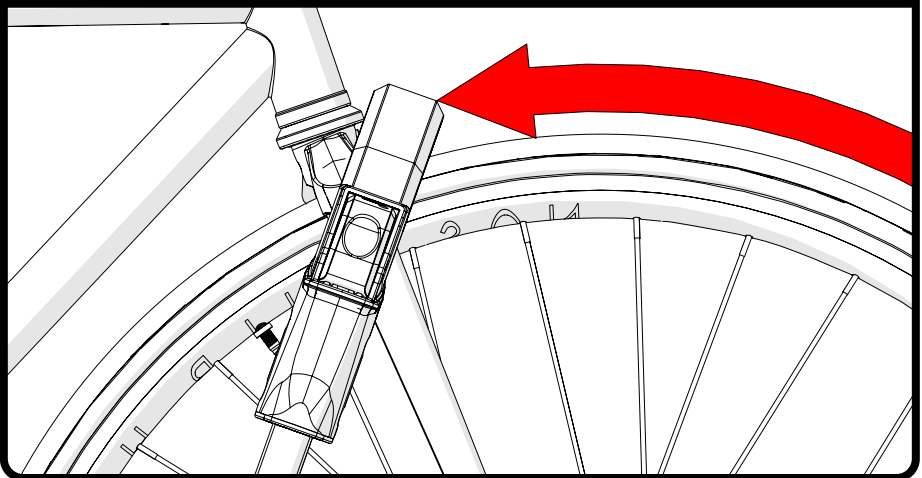

**STEP 5.** Ensure rear bicycle tire is properly seated in the rear cradle. Feed strap through ratchet pawl and pull strap down to tighten.

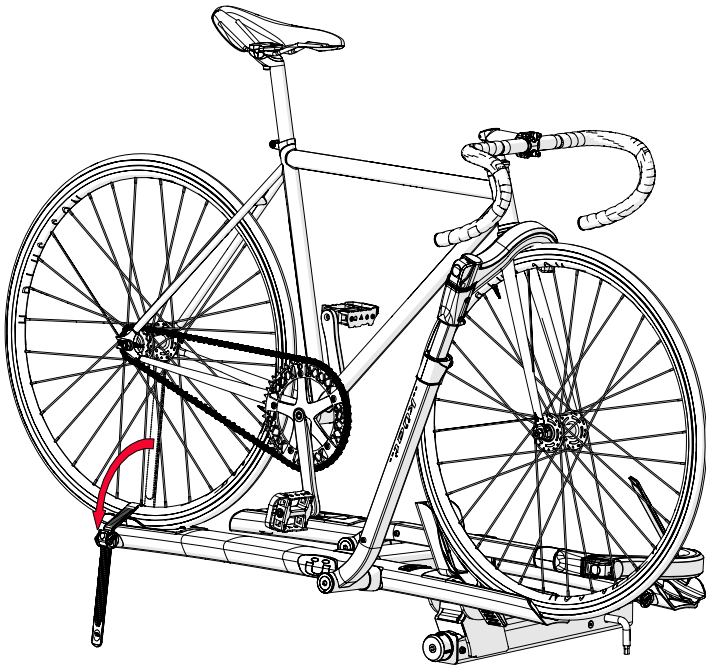

**NOTE:** When loading bicycles with 20"-24" front tires the included adapter must be used. If you require an additional adapter, please contact Kuat Racks directly by calling toll free 1(877)822-5828, or by emailing us at [info@kuatracks.com](mailto:info@kuatracks.com) and a 20"-24" adapter kit will be provided.

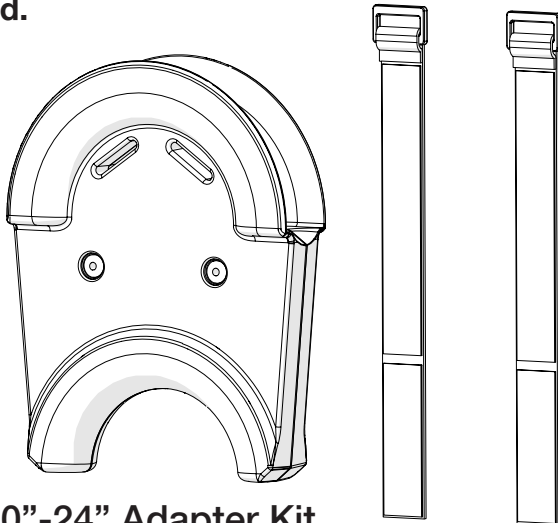

20"-24" Adapter Kit

**NOTE:** Front Tire Safety Strap must be used when driving over rough terrain or with bicycles 35 lbs or heavier.

**NOTA:** Se debe utilizar la correa de seguridad del neumático delantero al conducir sobre terreno accidentado o con bicicletas de 35 libras o más.

**REMARQUE:** La sangle de sécurité des pneus avant doit être utilisée lors de la conduite sur un terrain accidenté ou avec des vélos pesant 35 lb ou plus

**PART NEEDED:**

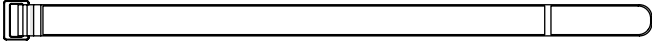

**x1 Front Tire Safety Strap**

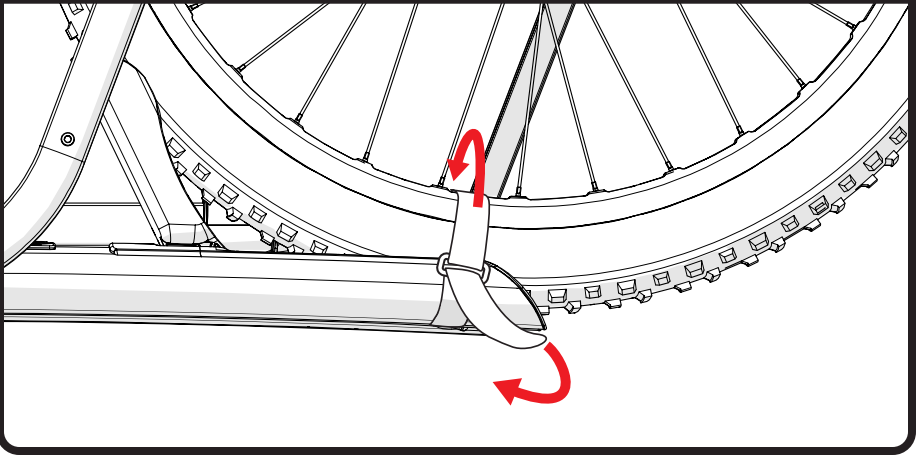

**NOTE:** If you wish to place the tire hook up to 1" (25mm) away from the fork, you must use the Front Tire Safety Strap. Caution must always be taken to ensure each bicycle is secured on the rack before any travel.

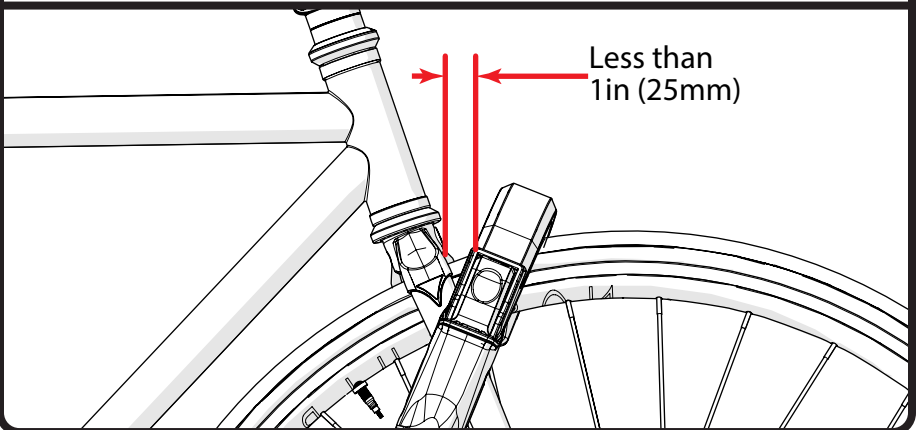

## Additional Notes

### Locking bicycles:

Loop the lock cable around the frame(s) and insert the latch tip into the lock on the outside tray.

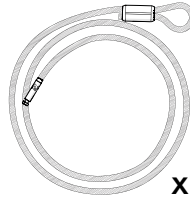

Parts  
Needed:

x1 Lock Cable

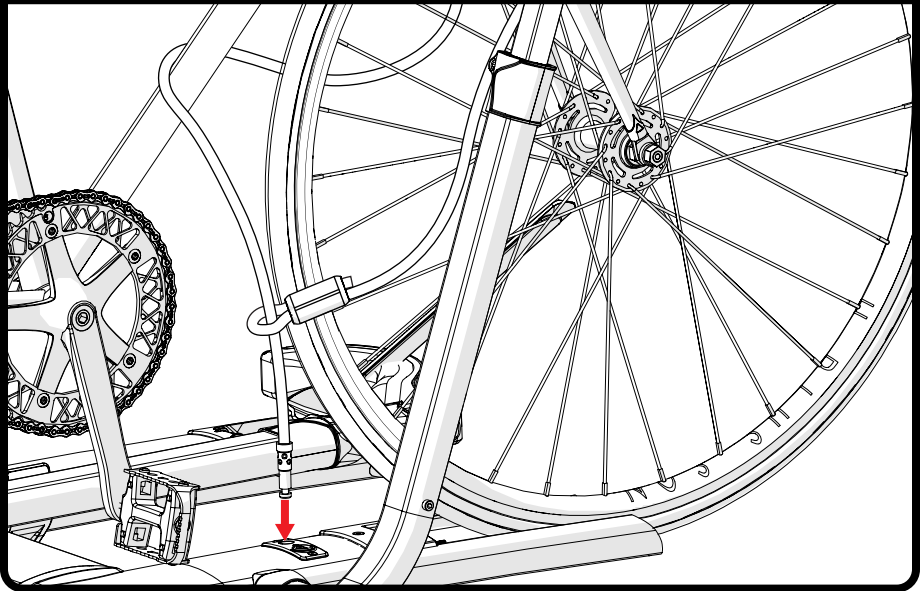

**NOTE:** With the tire hooks folded down, the tire hook next to the pivot handle can be used to gain leverage over the pivot handle making it easier to disengage the pivot.

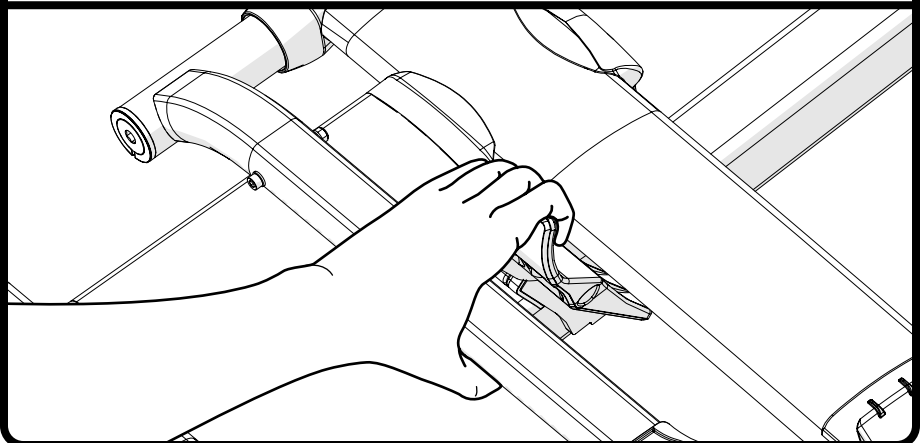

**NOTE:** The rack can be tilted away providing additional clearance for trunk or rear hatch access.

**NOTA:** Le support peut être incliné pour fournir davantage dégagement pour l'accès au coffre ou au hayon arrière.

**REMARQUE:** El estante se puede inclinar para proporcionar más espacio libre para acceso al maletero o a la escotilla trasera.

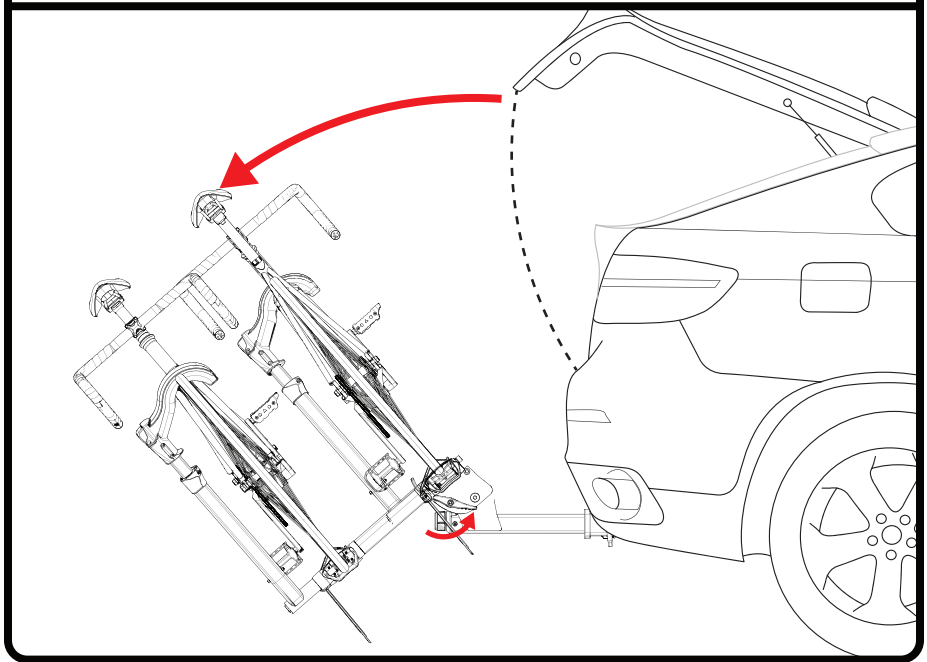

## Tips and Tricks

- Periodically check all nuts and bolts for proper tightness, not doing so can lead to premature wear or rack failure.
- Lubricate the lock mechanisms using a light oil. Keep the cover on the hitch pin lock at all times.
- The 8mm hex key on the hitch pin can be used to tighten and loosen the cam system.
- Keeping your rack clean will help prevent corrosion and keep the rack working correctly for years.
- The pivot handle is also designed to be used as foot pedal when lowering the trays.
- Make sure the bicycles' tires are properly inflated and free of leaks. Bicycles can become loose if a tire deflates while in the rack.

# Kuat Rack Warnings

## SHERPA™ 2.0

Number Of Bikes

2

Weight Per Bike

40 lb

18.2 kg

RV Use

See RV  
Compatibility  
Warning

Max Wheelbase

47 in

1194 mm

Max Tire Width

3.0 in

76 mm

### WARNINGS

- Follow instructions for proper assembly, mounting and loading procedures.
- Check tightness of all bolts and screws periodically.
- Make sure the rack and your vehicle receiver are in good working condition before each use.
- Do not use rack off-road.
  - Gravel roads not considered off-road.
- Do not use hitch extenders with this product.
- Do not use rain or wind-covers or tarps with this product.
- Place the front tire clamp next to the front fork.
- Do not take through automatic carwash.
- Do not use front tire bicycle fenders with this product
- Front Tire Safety Strap must be used with bicycles 35 lbs or heavier.
- If the ratchet arm and/or tire tray are directly in front of vehicle's exhaust, there is a risk of the plastic parts melting. Consider purchasing our Hi-Lo Pro accessory to help adjust the rack height and avoid rack damage.

If you have questions or problems with your rack, please contact Kuat Racks directly by calling toll free 1(877)822-KUAT, or by email: [info@kuatracks.com](mailto:info@kuatracks.com).

### ADVERTENCIAS

- Revise el apriete de todos los pernos y tornillos de forma periódica.
- NO LO USE EN TODO TERRENO.
- Siga las instrucciones para un ensamblaje propio, procedimientos de montaje y procedimientos de carga.
- Asegúrese que el portabicicletas y el receptor de su vehículo estén en buenas condiciones antes de cada uso.
- No use ganchos extensibles con este producto.
- No use cubiertas o forros para lluvia o viento con este producto.
- Ponga la tijera de la llanta frontal del lado de los brazos de carga frontales.
- No utilice guardabarros bicicleta deneumáticos delanteros con este producto.
- No lo pase a través de un lavado de autos automático.
- Frente Correa de seguridad del neumático debe ser utilizado cuando se conduce por terrenos accidentados o con las bicicletas 15.9 kgs o más pesados

Si tiene usted alguna pregunta o problema con su portabicicletas, por favor contacte a Kuat Racks directamente llamando a nuestro número gratuito 1(877)822-KUAT, o por e-mail: [info@kuatracks.com](mailto:info@kuatracks.com).

### AVERTISSEMENTS

- Vérifier le serrage des boulons et des vis périodiquement.
- NE PAS UTILISER À L'EXTÉRIEUR DU RÉSEAU ROUTIER (OFF-ROAD).
  - Bien suivre les instructions de processus d'assemblage, montage et chargement.
  - S'assurer du bon fonctionnement du rack et du véhicule avant l'utilisation.
  - Ne pas combiner ce produit avec des rallonges de l'attache-remorque.
  - Ne pas utiliser les housses contre la pluie ou le vent, ni les bâches avec ce produit.
  - Placer le crampon du pneu avant à côté de la fourche avant du vélo.
  - No utilice guardabarros bicicleta de neumáticos delanteros con este producto.
  - Ne pas laisser le rack sur le véhicule lors des lavages automatiques (car wash)
  - Front Tire Sangle de sécurité doit être utilisé lors la conduite sur un terrain accidenté ou avec des bicyclettes 15,9 kg ou plus lourds.

Si vous avez des questions ou si vous éprouvez des problèmes avec votre rack, nous vous à nous contacter chez Kuat Racks au numéro sans frais: 1(877)822-KUAT ou par e-mail: [info@kuatracks.com](mailto:info@kuatracks.com)

# NO WORRIES LIMITED WARRANTY

We stand behind our products, and our customer service reps are waiting to help you out if you have any problems with your product. Our limited warranty covers your purchase for life. You can review our limited warranty on our website or call customer service at the number below if you have questions or need a repair, replacement, refund, or a copy of the limited warranty.

**[www.kuat.com/warranty](http://www.kuat.com/warranty)**

## **Questions or comments?**

Drop us an email or call us directly!

**[kuat.com](http://kuat.com) | [info@kuat.com](mailto:info@kuat.com) | [877.822.5828](tel:877.822.5828)**

# Küat RV Compatibility Warning

Küat's receiver hitch-mounted bicycle racks may be used with some recreational vehicles (RVs) as described below. Many types of RVs subject the rack and bicycles on it to high forces and extreme movements. As a result, Küat does not recommend using our receiver hitch-mounted products on RVs that will likely expose the rack to unacceptable conditions.

Küat's standard warranty will cover use of any of its 2-inch receiver hitch-mounted bicycle racks on motorhomes (as defined in 49 C.F.R. 571.3) satisfying all of the following requirements:

The receiver hitch is directly attached to the motorhome chassis, not just to the bumper;

The rear-most point of the receiver hitch where the bicycle rack will be attached is no more than 64 inches from the rear axle of the motorhome; and

The vehicle is a class B type motorhome as described below.

Class B type motorhomes are commonly known as van conversions and comprise a completed van-type vehicle which has been altered to provide temporary living quarters. Class B type motorhomes have a gross vehicle weight rating of 10,000 lbs or less.

In addition, the 2 inch receiver Transfer™ v2 and the 2-inch receiver Piston Pro X may be used on RVs (both motorhomes and trailers) satisfying all of the following requirements:

The receiver hitch is directly attached to the RV chassis, not just to the bumper; and

The bicycle rack is in the 2-bike configuration with no add-on unit attached.

Please check the Warnings section of the User Guide for load weight limits applicable to your rack when used on an RV. Lower weight limits apply.

Even if the conditions above are met, any RV may be operated in a way that will expose Küat's products to conditions that they are not designed to handle. The operator of the RV is responsible to operate the RV in a manner that will not overload the rack, such as by excessive speed over rough roads or speed bumps, rapid turning movements, driving the RV over changes in gradient that will bring the rack in contact with the ground, or other similar actions.



